

POSITIVE INPUT VENTILATION (PIV)

A close-up photograph of a blue mechanical ventilation unit. The unit is cylindrical and has a blue plastic housing. It is connected to two white flexible ducts. The duct on the left is corrugated and has a grey pleated filter at its end. The duct on the right is smooth and has a white pleated filter at its end. Dotted lines connect the filters to the main body of the unit. The background is white.

CREATING
A HEALTHY
INDOOR
ENVIRONMENT

NUAIRE'S PEDIGREE

Proud to Build British

Nuaire is a world leader in the design and manufacture of fans and ventilation systems. We put our energy into efficient ventilation so you don't waste yours.

Nuaire is a British company that designs and manufactures innovative ventilation products for the residential and commercial sectors. We are proud to be recognised for our expertise, commitment to innovation and the outstanding quality of our products and customer service.

Our people are at the heart of Nuaire, we have more than 400 experienced staff based at our headquarters, with a further 65 technical sales engineers throughout the UK and Ireland.



MADE IN
GREAT BRITAIN



Nuaire's technical application team can offer expert advice and support to help you make the right choice in your ventilation strategy. Providing a simple, quick selection or offering advice on compliance with the very latest building regulations and environmental issues, we are here for you every step of the way.

Based in South Wales, our factory covers 18,000m², allowing us to manufacture almost all of our products on site; from small bathroom fans to large air handling units.

In recent years Nuaire has invested millions of pounds into a new manufacturing plant to support its plans for growth.



"Our manufacturing facility is approximately 4 x the size of the Wembley pitch"



GETTING IT
RIGHT FROM
THE START





Advice On Compliance

Stay ahead of the latest building regulations and make the best product and fabric choices.



Over 65 Sales Staff

Field and office based staff to support you at every stage.



Gold Star Aftercare

Our comprehensive product warranty and dedicated after sales support gives you peace of mind.



The Full Service

Help with product selection, detailed parts lists and fast delivery to ensure you meet your deadline and budget.



POSITIVE INPUT VENTILATION (Alternative Systems)

NUAIRE
INVENTED PIV
OVER 40
YEARS AGO

Nuaire's alternative approach to continuous mechanical ventilation is Positive Input Ventilation (PIV).



THE ALTERNATIVE METHOD FOR BUILDING REGULATIONS



Invented by Nuaire and installed in thousands of dwellings each year, PIV can be a more cost-effective and simple to install ventilation solution, whilst still meeting building regulations.

It has become the UK's most popular alternative method of low energy, cost-effective ventilation.

PIV How does it work?

CREATES A HEALTHY LIVING ENVIRONMENT

Significantly improves indoor air quality by removing indoor air pollutants such as carbon dioxide and keeping out external pollutants such as traffic fumes and pollen.

MOISTURE AND CONDENSATION ARE DRIVEN OUT

The filtered air gently pressurises the home from inside out, forcing out the stale air.



NO NEED TO OPEN WINDOWS TO VENTILATE

Clean, fresh air is continuously drawn in through the lofts natural leakage points, passed through the filters and fed into the property via a central hallway diffuser.

Nuaire offers solutions for homes with a loft, without a loft and even three-storey homes.

The simple installation of DRIMASTER-ECO is fully compliant to building regulations and only requires minimal maintenance.



For homes without a loft, the Flatmaster product is compact and can be fitted in a convenient location, such as a utility cupboard or hallway.



PIV systems are proven to be effective units in significantly reducing radon gas levels in affected areas. The system works by gently supplying fresh, filtered air into the property. This process changes the direction of airflow within the dwelling to force the air contaminated by radon out of the home.

PIV technology is also proven to help allergy and asthma sufferers by guaranteeing filtered, quality indoor air. The DRIMASTER-ECO range averages at approximately 0.17 watts/l/s, with solar gains up to 550kw/hr/year, PIV is an ideal low power ventilation solution.

The DRIMASTER eco Range

The DRIMASTER-ECO range provides whole home ventilation using the Positive Input Ventilation principle, which introduces fresh filtered air into the dwelling at a continuous rate, encouraging movement of air from inside to outside. To achieve this the unit is mounted in the loft space, drawing air through the filters and inputting it, at ceiling level, into the property.

The DRIMASTER-ECO units are fitted with an internal temperature sensor, which continuously monitors the temperature in the loft and boosts the air volume when the loft temperature is above a set level (heat recovery mode). If the loft temperature becomes excessive, the unit will switch to standby mode (no airflow). Once installed, the airflow can be set to suit the house size and if required, the way it responds to the temperature changes within.



DRI-ECO-HC

The DRI-ECO-HC enhances Nuair's PIV technology with the added benefit of having the system controls located in the contemporary ceiling diffuser. This unique feature offers the homeowner complete control of the unit, without having to enter the loft space. Not only can settings be altered with the push of a button on the contemporary diffuser, but there is also a 7 segment display which notifies the user of the need for filter change and what setting the DRIMASTER-ECO is running on.



DRI-ECO-LINK-HC INSTALLATION

Technical

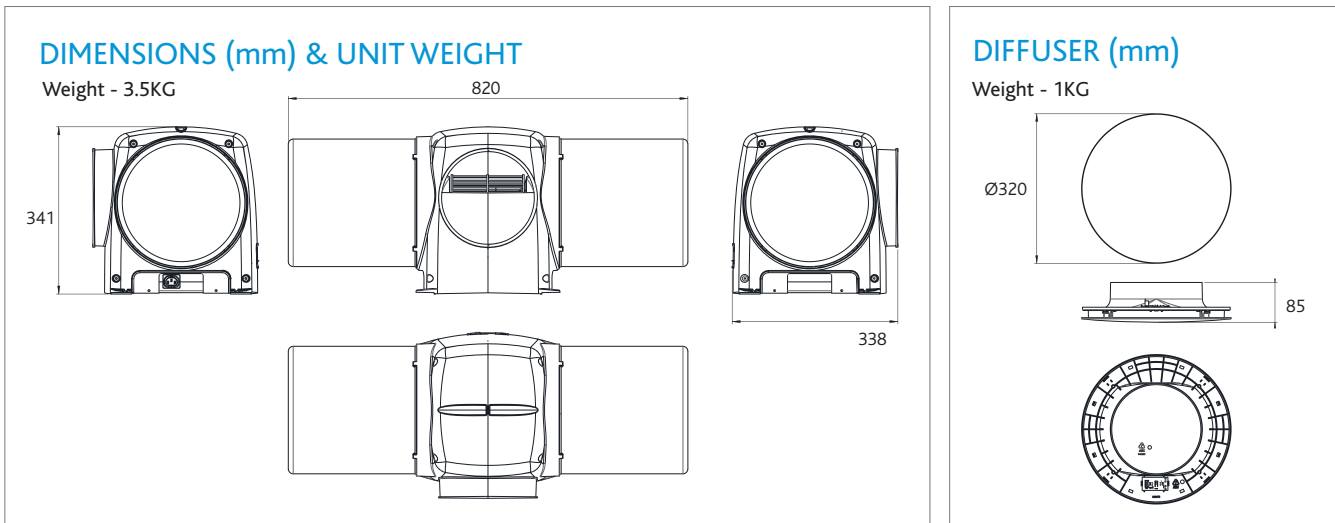

Wiring

The unit is supplied with a pre-wired power supply. This power supply unit has a metal bracket incorporating fixing holes, which should be used to fit the power supply to a suitable surface e.g. a wooden joist. The fan unit is also supplied with a fused spur.

The 2 core mains cable from the power supply should be connected to a fixed wiring installation in accordance with current IEE wiring regulations.

Electrical Details

	Voltage	Consumption
DRI-ECO-HC	230V 1ph 50Hz	1.6W(min) 17W(max)

Typical Installation

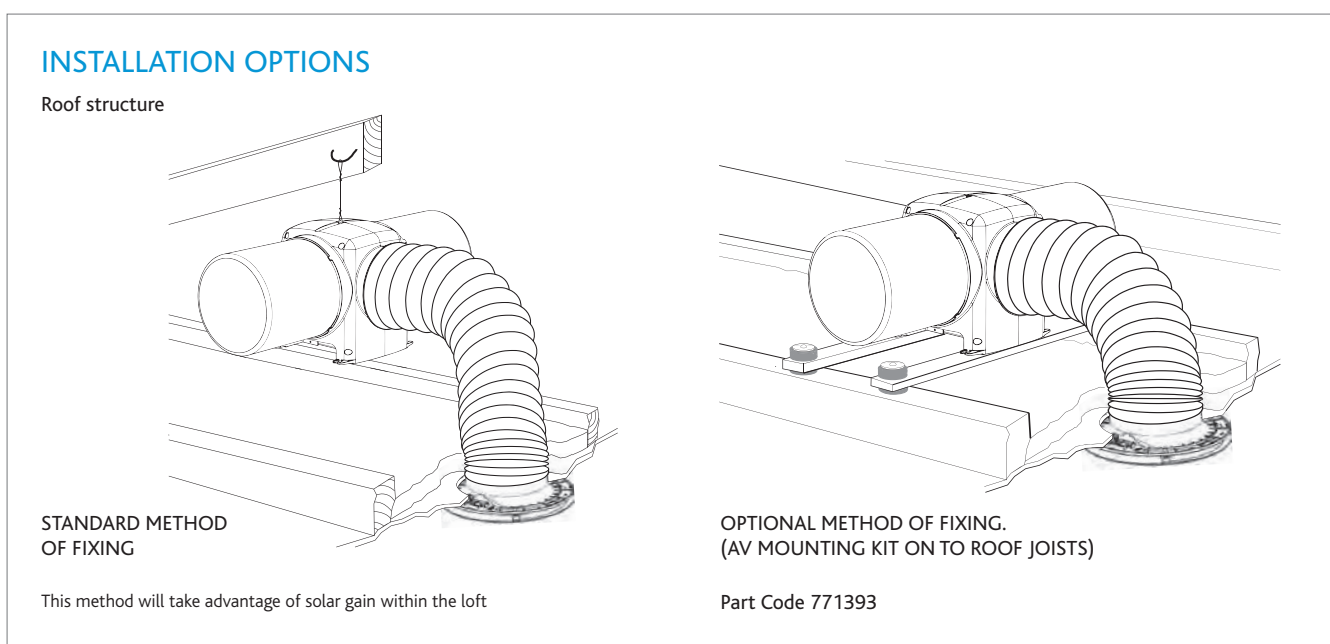

NUAIRE'S PIV: HALL CONTROL

DRI-ECO-LINK-HC

The DRI-ECO-LINK-HC sees Nuair offer its long-standing PIV technology alongside wireless control and sensor capabilities.

By offering a choice of interactive sensors Nuair has created an adaptable, market-leading PIV product. Homeowners can choose to use one or all of the sensors available for optimum system performance, in addition to the unique controls sited at our re-designed, modern ceiling diffuser.



DRI-ECO-LINK-HC INSTALLATION

Technical

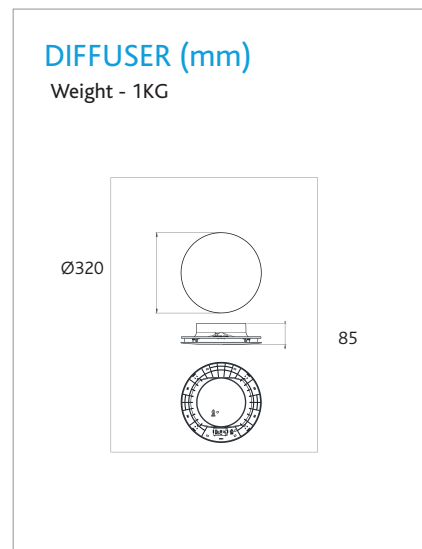
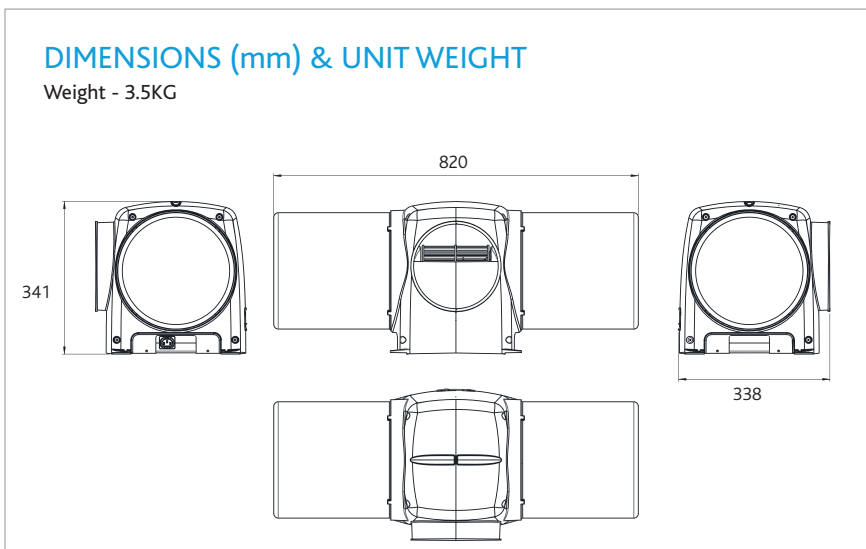

Wiring

The unit is supplied with a pre-wired power supply. This power supply unit has a metal bracket incorporating fixing holes, which should be used to fit the power supply to a suitable surface e.g. a wooden joist. The fan unit is also supplied with a fused spur.

The 2 core mains cable from the power supply should be connected to a fixed wiring installation in accordance with current IEE wiring regulations.

Electrical Details

	Voltage	Consumption
DRI-ECO-LINK-HC	230V 1ph 50Hz	1.6W(min) 17W(max)

Typical Installation

INSTALLATION OPTIONS

Roof structure

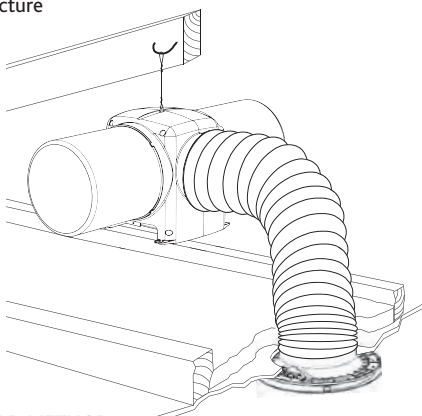

STANDARD METHOD OF FIXING

This method will take advantage of solar gain within the loft

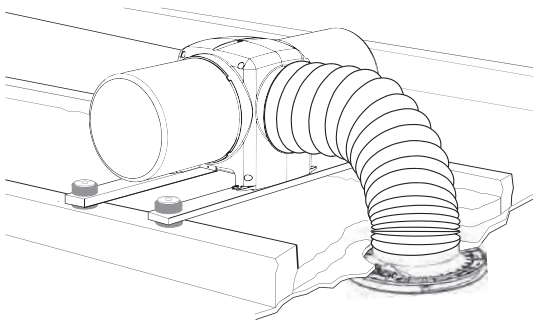

OPTIONAL METHOD OF FIXING.
(AV MOUNTING KIT ON TO ROOF JOISTS)

Part Code 771393

Remote/Wired Sensors



DRI-ECO-2S

A 2 button switch that gives the homeowner control to increase the airflow within the property when required.



DRI-ECO-CO2

A Carbon Dioxide CO2 sensor which must be wired directly in to the mains power supply. This ancillary will provide complete confidence in the property's air quality by automatically boosting the fan speed should high levels of CO2 rise above a set point.



DRI-ECO-RM

The Remote Monitoring device will allow readings to be taken from outside the property to determine how long the unit has been running and the operating speed of the unit. This will benefit the social housing provider when checks are carried out to ensure measures put in place to alleviate condensation issues are being adhered to, without having to enter the property.



DRI-ECO-RH

Nuaire's latest Relative Humidity sensor monitors the humidity levels within the home and instructs the unit within the loft to adjust the speed in order to maintain optimum comfort.

DRI-ECO-HEAT-HC

The unique DRI-ECO-HEAT-HC incorporates all of the wireless functions of our DRI-ECO-LINK-HC unit but with the benefit of an integral heating element, located between the flexible duct and ceiling diffuser.

This heating component will temper the air which is distributed through the property via the ceiling diffuser, thus ensuring a comfortable living environment. This pioneering design sees the low watt heater (400w) react efficiently and effectively, guaranteeing an economically friendly product.

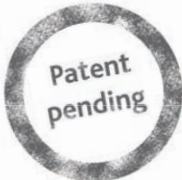

DRI-ECO-HEAT-HC INSTALLATION

Technical

DIMENSIONS (mm) & UNIT WEIGHT
Weight - 3.5KG

DIFFUSER (mm)
Weight - 1KG

INTEGRAL HEATER (mm) Ø316
Weight - 2KG

Wiring

The unit is supplied with a pre-wired power supply. The fan unit is also supplied with a fused spur. The 3 core mains cable from the power supply should be connected to a fixed wiring installation in accordance with current IEE wiring regulations.

Electrical Details

	Voltage	Consumption
DRI-ECO-HEAT-HC	230V 1ph 50Hz	1.6W(min) 17W(max)

Standard running: 1.6W(min) 15.3W(max) Up to 400W with heater at full load.

Typical Installation

INSTALLATION OPTIONS

Roof structure

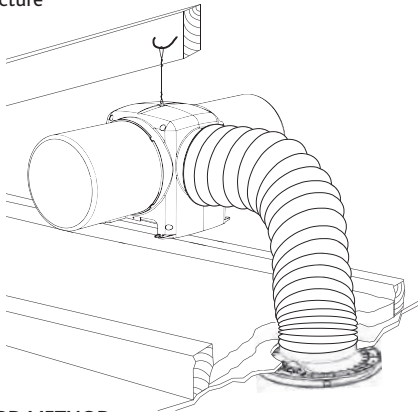

STANDARD METHOD OF FIXING

This method will take advantage of solar gain within the loft

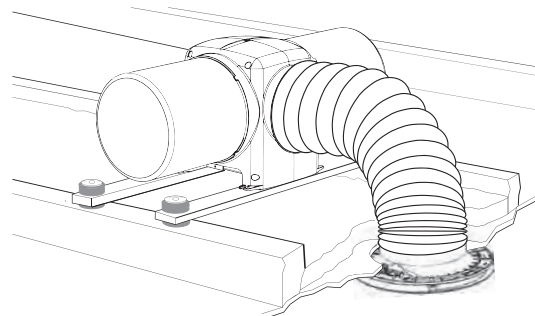

OPTIONAL METHOD OF FIXING.
(AV MOUNTING KIT ON TO ROOF JOISTS)

Part Code 771393

Remote/Wired Sensors



DRI-ECO-4S

A 4 button switch that gives the homeowner control to increase the airflow within the property when required.



DRI-ECO-CO2

A Carbon Dioxide CO2 sensor which must be wired directly in to the mains power supply. This ancillary will provide complete confidence in the property's air quality by automatically boosting the fan speed should high levels of CO2 rise above a set point.



DRI-ECO-RM

The Remote Monitoring device will allow readings to be taken from outside the property to determine how long the unit has been running and the operating speed of the unit. This will benefit the social housing provider when checks are carried out to ensure measures put in place to alleviate condensation issues are being adhered to, without having to enter the property.



DRI-ECO-RH

Nuaire's latest Relative Humidity sensor monitors the humidity levels within the home and instructs the unit within the loft to adjust the speed in order to maintain optimum comfort.

Consultants Specification

Low energy Positive Input Ventilation system for use in homes with a loft.

The unit shall be robustly constructed from ABS polymer.

Flame retardant filters of G4 grade, surface area approximately 0.47m² (with 5 year typical maintenance period) shall be fitted, which may be removed from the unit without the use of tools. The filters shall be arranged such as to prevent their obstruction in the loft space.

The unit shall incorporate a forward curved centrifugal impeller and high efficiency brushless DC motor fitted with sealed for life, selflubricating bearings and locked rotor protection. The unit's average power consumption shall be 0.17 watts per l/s airflow; excluding power consumed by the heating element within DRI-ECO-HEAT-HC when running.

The unit shall be supplied with a 2m length of flexible ducting and all necessary connectors and fittings.

The unit shall weigh 3.5kg and we recommend the unit is suspended from the roof structure. The unit shall be supplied with a purpose designed flame retardant polymer diffuser for efficient, directable air input. The diffuser design shall be optimised for use in areas where smoke detectors are fitted. The unit shall include 5 programmable temperature control strategies, 6 volume control settings and an optional high duty boost setting, providing an airflow rate of 70 l/s for optimum performance and occupant comfort. All control/duty strategies shall be optimised for maximum performance and occupant comfort.

An internal run motor shall record the unit's operational time. For information on reducing radon egress, it is suggested that the details given in Positive Pressurisation: A BRE Guide to Radon Remedial Measures in Existing Dwellings may be considered.

DRI-ECO-HC

The DRI-ECO-HC fan unit includes an internal sensor to regulate the fan speed according to the temperature of the loft. The internal sensor will increase airflow to the dwelling when the temperature in the loft space is anywhere between 19-24 degrees celsius. The unit's 'Fixed Temperature Heat Recovery' strategy shall be achieved via a sensor located in the unit and shall improve energy performance accordingly. This unit has all of the controls for the fan in the ceiling vent allowing the user to control, programme and monitor the unit from inside the property.

The unit shall be offered with a 7 year warranty.

DRI-ECO-LINK-HC

The DRI-ECO-LINK-HC fan unit includes an internal sensor to regulate the fan speed according to the temperature of the loft. The internal sensor will increase airflow to the dwelling when the temperature in the loft is anywhere between 19-24 degrees celsius. If the DRI-ECO-RH is purchased then the temperature sensor integral to this ancillary will be used to communicate with the PIV unit and should the temperature in the loft become warmer than the dwelling, the fan will boost. The unit's 'Fixed Temperature Heat Recovery' strategies shall be achieved via these sensors and shall improve energy performance accordingly. This unit has all the controls for the fan in the ceiling vent allowing the user to control, programme and monitor the unit from inside the property. It also has the ability to be controlled using a radio frequency function and can be boosted from a remote wall mounted switch, remote CO2 detector and an remote humidity sensor.

The unit shall be offered with a 7 year warranty; 1 year parts and labour, remaining years parts only. This warranty is void if the equipment is modified without authorisation, is incorrectly applied, misused, disassembled or not installed, commissioned and maintained in accordance with the details contained in the I&M manual and general good practice.

DRI-ECO-HEAT-HC

The DRI-ECO-HEAT-HC fan unit includes an internal sensor to regulate the fan speed according to the temperature of the loft. The internal sensor will increase airflow to the dwelling when the temperature in the loft is anywhere between 19-24 degrees celsius. If the DRI-ECO-RH is purchased then the temperature sensor integral to this ancillary will be used to communicate with the PIV unit and should the temperature in the loft become warmer than the dwelling, the fan will boost. The unit's 'Fixed Temperature Heat Recovery' strategies shall be achieved via these sensors and shall improve energy performance accordingly. This unit has all the controls for the fan in the ceiling vent allowing the user to control, programme and monitor the unit from inside the property. A heater section incorporating a 400w heating element shall be fitted to the diffuser. It shall be electronically controlled so as to minimise energy use. A temperature sensor shall be fitted to the outlet of the heater and will control the output of the heater in an attempt to maintain the set point. The set point will be adjustable between 6°C and 20°C. It also has the ability to be controlled using a radio frequency function and can be boosted from a remote wall mounted switch, remote CO2 detector and an remote humidity sensor.

The unit shall be offered with a 7 year warranty; 1 year parts and labour, remaining years parts only. This warranty is void if the equipment is modified without authorisation, is incorrectly applied, misused, disassembled or not installed, commissioned and maintained in accordance with the details contained in the I&M manual and general good practice.

Nuaire invented PIV over 40 years ago!

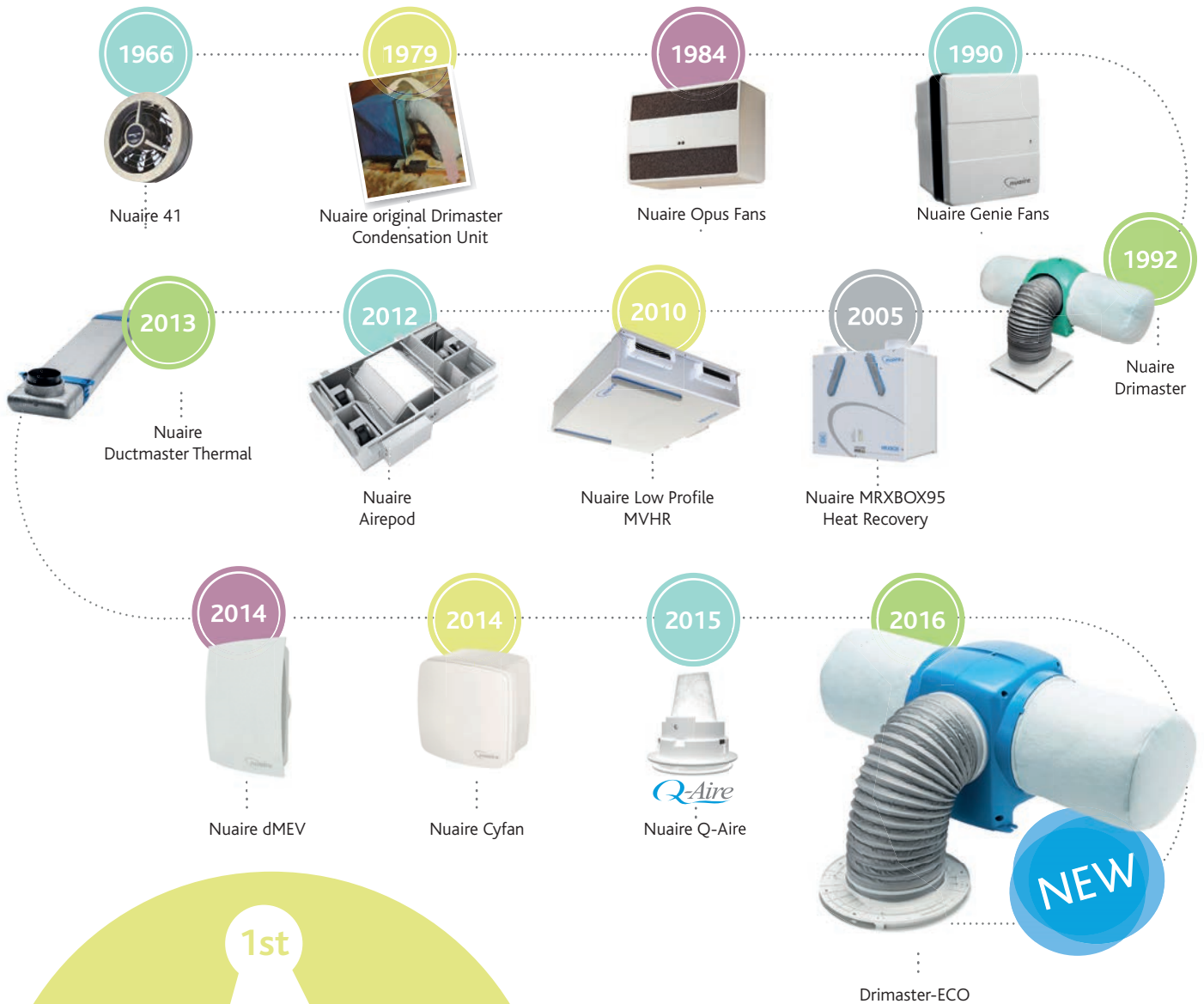

1st

OUR REPUTATION IS BASED ON PROVEN ACHIEVEMENTS

1st to introduce the Positive Input Ventilation strategy

1st to develop MVHR and MEV systems

1st to offer REVIT compatible BIM files

1st to provide a free design service to customers

Wiring

The unit is supplied with a pre-wired power supply. This power supply unit has a metal bracket incorporating fixing holes, which should be used to fit the power supply to a suitable surface e.g. a wooden joist. The fan unit is also supplied with a fused spur.

The 2 core mains cable from the power supply should be connected to a fixed wiring installation in accordance with current IEE wiring regulations.

Electrical Details

	Voltage	Consumption
DRI-ECO-LC	230V 1ph 50Hz	1.6W(min) 17W(max)

Typical Installation

INSTALLATION OPTIONS

Roof structure

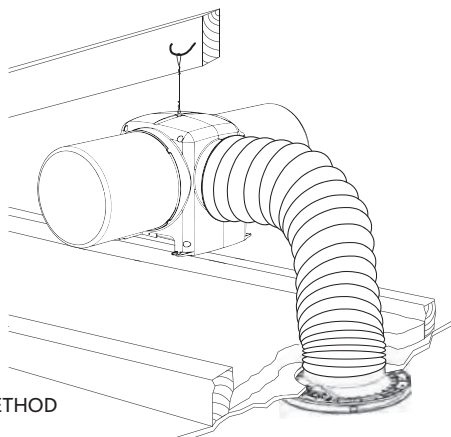

STANDARD METHOD OF FIXING

This method will take advantage of solar gain within the loft

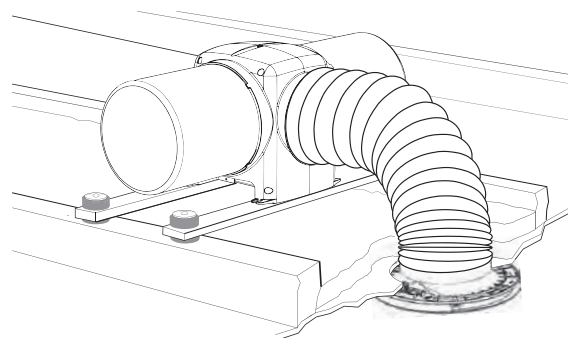

OPTIONAL METHOD OF FIXING.
(AV MOUNTING KIT ON TO ROOF JOISTS)

Part Code 771393

NUAIRE'S PIV: LOFT CONTROL

DRI-ECO-3STOREY

The DRI-ECO-3STOREY is the only unit within the DRIMASTER-ECO range which is suitable for install within three storey properties, by using an intumescent aluminium diffuser in order to meet fire regulation standards.

The unit itself works by drawing fresh air in from the loft space and dispersing it through the property via a powder coated ceiling diffuser, which provides a 1 hour fire-block. This technology is fundamental to the well-being of the home owner and allows Nuaire to offer a ventilation solution for every property type.



Technical

DIMENSIONS (mm) & UNIT WEIGHT

Weight - 3.5KG

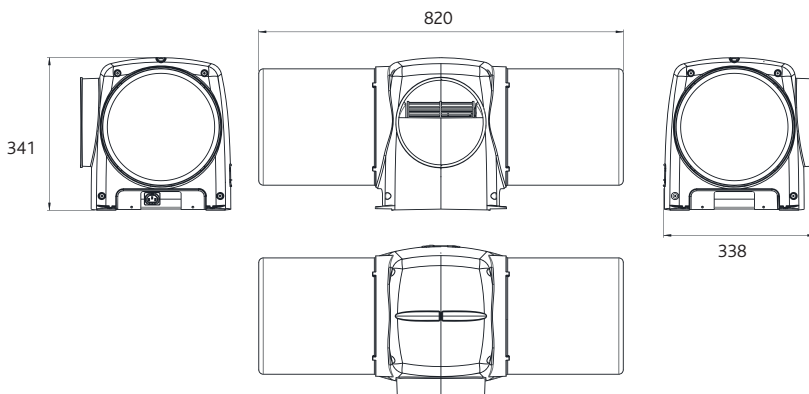

AIR DIFFUSER FOR THREE STOREY DWELLINGS

For use in stairwells of three storey properties, the optional powder-coated aluminium diffuser with 'fire-block' provides 1 hour of fire resistance in accordance with BS476 Part 20 and ISO834.

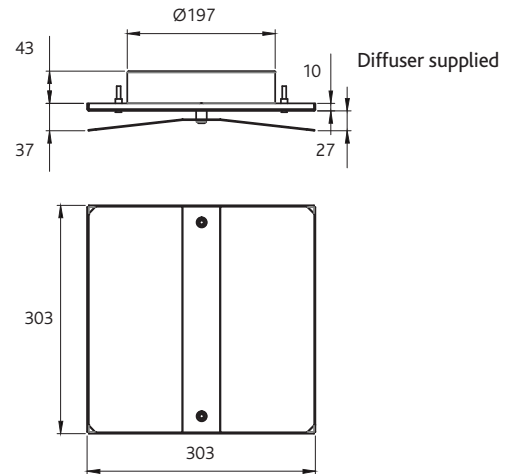
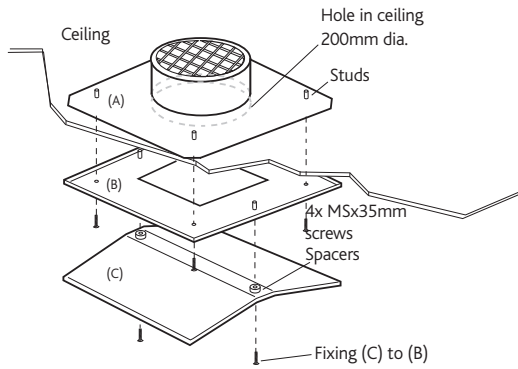

Wiring

The unit is supplied with a pre-wired power supply. This power supply unit has a metal bracket incorporating fixing holes, which should be used to fit the power supply to a suitable surface e.g. a wooden joist. The fan unit is also supplied with a fused spur.

The 2 core mains cable from the power supply should be connected to a fixed wiring installation in accordance with current IEE wiring regulations.

Electrical Details

	Voltage	Consumption
DRI ECO-3STOREY	230V 1ph 50Hz	1.6W(min) 17W(max)

Typical Installation

INSTALLATION OP*

Roof structure

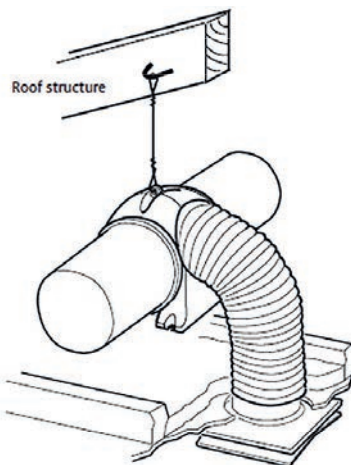

STANDARD METHOD OF FIXING

This method will take advantage of solar gain within the loft

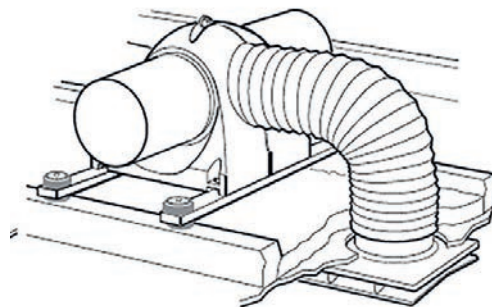

Part Code 771393

Consultants Specification

Low energy Positive Input Ventilation system for use in homes with a loft.

The unit shall be robustly constructed from ABS polymer.

Flame retardant filters of G4 grade, surface area approximately 0.47m² (with 5 year typical maintenance period) shall be fitted, which may be removed from the unit without the use of tools. The filters shall be arranged such as to prevent their obstruction in the loft space.

The unit shall incorporate a forward curved centrifugal impeller and high efficiency brushless DC motor fitted with sealed for life, selflubricating bearings and locked rotor protection. The unit's average power consumption shall be 0.17 watts per l/s airflow.

The unit shall be supplied with a 2m length of flexible ducting and all necessary connectors and fittings.

The unit shall weigh 3.5kg and we recommend the unit is suspended from the roof structure. The unit shall be supplied with a purpose designed flame retardant polymer diffuser for efficient, directable air input. The diffuser design shall be optimised for use in areas where smoke detectors are fitted. The unit shall include 5 programmable temperature control strategies, 6 volume control settings and an optional high duty boost setting, providing an airflow rate of 70 l/s for optimum performance and occupant comfort. All control/ duty strategies shall be optimised for maximum performance and occupant comfort.

An internal run motor shall record the unit's operational time. For information on reducing radon egress, it is suggested that the details given in Positive Pressurisation: A BRE Guide to Radon Remedial Measures in Existing Dwellings may be considered.

DRI-ECO-LC

The DRI-ECO-LC fan unit includes an internal sensor to regulate the fan speed according to the temperature of the loft. The internal sensor is to increase airflow to the dwelling when the loft reaches a temperature anywhere between 19-24 degrees celsius. The units 'Fixed Temperature Heat Recovery' strategy shall be achieved via a sensor located in the unit and shall improve energy performance accordingly.

The unit shall be offered with a 5 year warranty; 1 year parts and labour, remaining years parts only. This warranty is void if the equipment is modified without authorisation, is incorrectly applied, misused, disassembled or not installed, commissioned and maintained in accordance with the details contained in the I&M manual and general good practice.

DRI-ECO-3STOREY

The DRI-ECO-3STOREY fan unit includes an internal sensor to regulate the fan speed according to the temperature of the loft. The internal sensor is to increase airflow to the dwelling when the loft reaches a temperature anywhere between 19-24 degrees celsius. The units 'Fixed Temperature Heat Recovery' strategy shall be achieved via a sensor located in the unit and shall improve energy performance accordingly. The aluminium ceiling vent supplied includes an intumescent closure element.

The unit shall be offered with a 5 year warranty; 1 year parts and labour, remaining years parts only. This warranty is void if the equipment is modified without authorisation, is incorrectly applied, misused, disassembled or not installed, commissioned and maintained in accordance with the details contained in the I&M manual and general good practice.

DRI-365

DRI-365 is a unique low-energy, loft mounted Positive Input Ventilation unit which provides whole home ventilation all year round.

The unit is fully automatic and intelligently decides which location to supply the air from. It utilises the solar gain within the loft during the colder months subsequently bringing in fresh air during the warmer months.



SUMMER

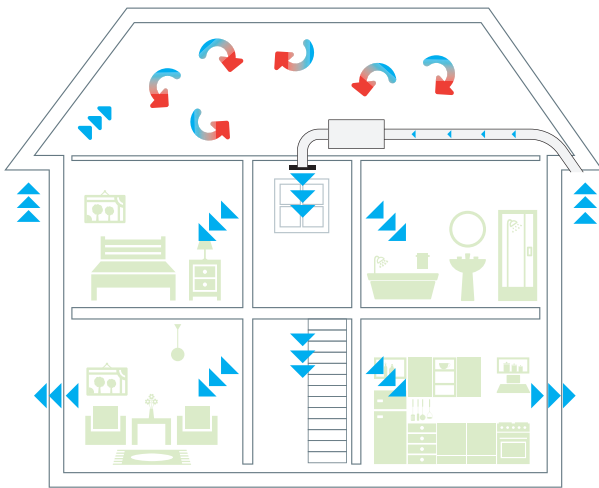

If the loft temperature is above 24°C air is drawn directly from outside, to provide background ventilation. In addition a boost switch is supplied to increase airflow when required.

WINTER

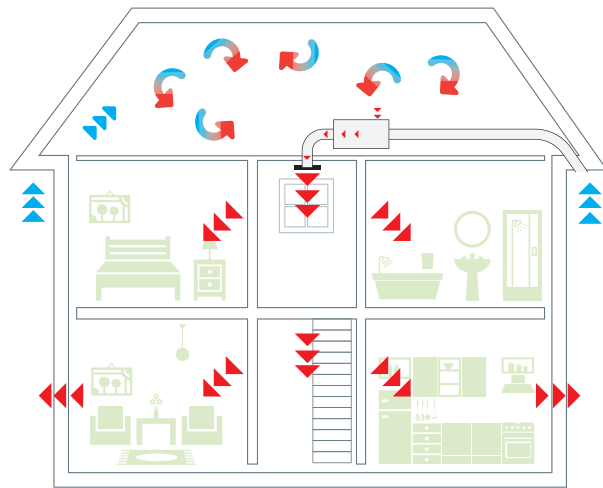

During the colder months tempered air is drawn from the loft space taking advantage of solar gain combined with the heat conducted through the ceiling of the home.

Technical

DIMENSIONS (mm) & UNIT WEIGHT

Weight - 10 KG

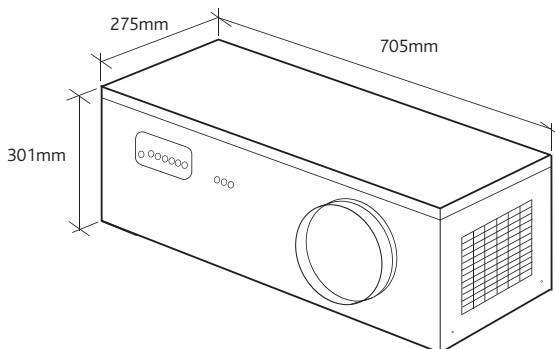

DIFFUSER (mm)

Weight - 1KG

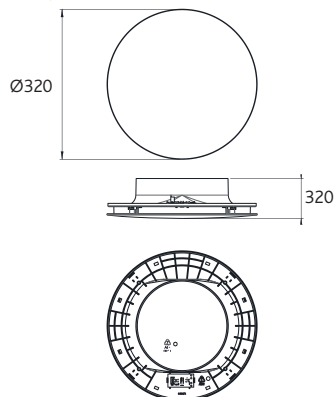

Electrical Details

	Voltage	Consumption
DRI-365	230V 1ph 50Hz	2W(min) 24W(max)

Typical Installation

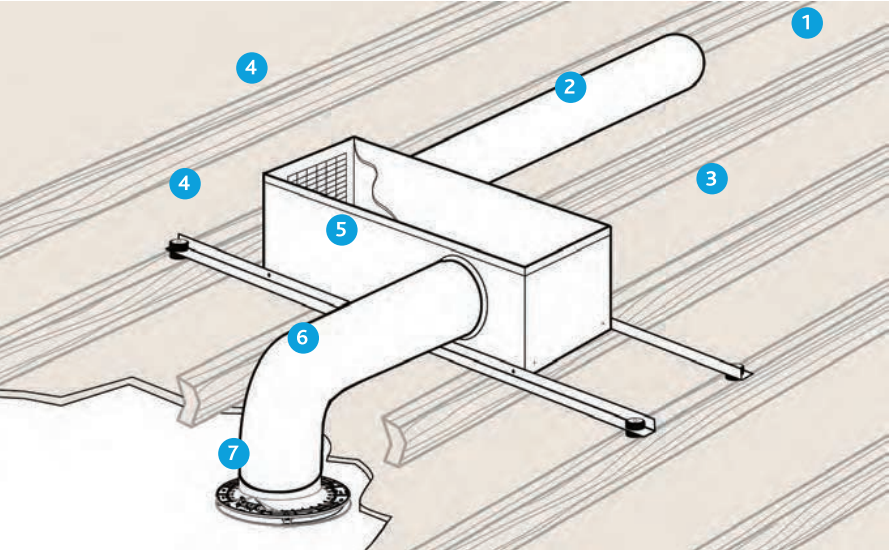

- 1 AIR FROM OUTSIDE
- 2 150mm DIA. FLEXIBLE DUCTING
- 3 SETTING SWITCH IS LOCATED ON THE REAR OF THE FAN FACE
- 4 AIR FROM LOFT
- 5 DRI-365
- 6 200mm DIA. FLEXIBLE DUCTING
- 7 DIFFUSER

Unit mounted on roof joists using two "L" shape metal brackets and AV mounts supplied with unit.

A remote boost switch comes as standard with the DRI-365 model. This must be wired directly in to the unit and can be used to control the fan with the choice of "Normal" or "Boost" functionality.

For installation the choice of either a Soffit Kit or Wall Kit must be made and ordered separately to the DRI-365 unit.

Please note part codes are DRI365-SOFITKIT and DRI365-WALLKIT.

ACCESSORIES



G4 FILTER



BOOST SWITCH

Consultants Specification

DRI-365

Nuaire DRI-365 ultra low energy Positive Input Ventilation unit.

The unit casing shall be manufactured from thermally lined pre-painted steel.

The casing shall have an easily removable panel to allow access for maintenance.

The unit shall incorporate a filter of G4 grade with an area of approximately 0.47m².

The unit shall incorporate a forward curved centrifugal impeller and high efficiency brushless DC motor fitted with sealed for life, selflubricating bearings and locked rotor protection.

The unit shall be supplied with a purpose designed polymer diffuser for efficient, directable air input using side blanking pieces supplied.

The ducting between the unit and the diffuser is supplied with unit.

The unit shall incorporate 6 volume control settings for maximum flexibility and occupant comfort. The unit is fully automatic. If the loft temperature is below 24°C then the unit will draw fresh air from the loft. If the loft temperature is above 24°C then cool fresh air will be drawn from outside the dwelling.

The unit shall incorporate two air inlets, one draws air from the loft, the other from outside via a 150mm dia. spigot.

The unit can be boosted to obtain maximum ventilation by the operation of a boost switch (supplied).

An internal monitor shall record the unit's operational time. For information on reducing radon egress, it is suggested that the details given in Positive pressurisation: A BRE Guide to Radon Remedial Measures in Existing Dwellings may be considered.

The unit shall be offered with a 5 year warranty; 1 year parts and labour, remaining years parts only. This warranty is void if the equipment is modified without authorisation, is incorrectly applied, misused, disassembled or not installed, commissioned and maintained in accordance with the details contained in the I&M manual and general good practice.

DRIMASTER-ECO PIV Product Selector

Page No.	6	8	10	14	16	19
Feature	DRI-ECO-HC	DRI-ECO-LINK-HC	DRI-ECO-HEAT-HC	DRI-ECO-LC	DRI-ECO-3STOREY	DRI-365
For properties with lofts						
Integral heater						
Compatible with relative humidity sensor						
Compatible with CO2 sensor						
Compatible with remote two-way boost switch						
Compatible with four-way remote switch with boost and heater control						
Compatible with Remote Monitoring device						
Easy accessible discreet commissioning and controls behind diffuser						
Controls/commissioning at unit						
Modern circular ceiling diffuser						
Aluminium intumescent diffuser						
5-year warranty						
7-year warranty						

KEY: DRI Drimaster (loft-mounted) ECO Eco-friendly HC Hall control (diffuser) HEAT Integral heater
 LC Loft control/unit 3STOREY 3 storey properties 365 Operates 365 days a year



Nuaire offers other forms of residential ventilation!

Dedication to innovative technology due to the increased demand for energy efficient homes means Nuaire can offer everything from simple bathroom fans, through to combined heating and ventilation systems with acoustic solutions for every property type.

For more information contact our Residential Sales Office on

029 2085 8500

or residential.enquires@nuaire.co.uk

www.nuaire.co.uk

EXTRACT FAN

Continuous and Intermittent



MVHR

Mechanical Ventilation with Heat Recovery



dMEV

Decentralised Mechanical Extract Ventilation



FLATMASTER

Positive Input Ventilation for homes without lofts



DRIMASTER-ECO

Positive Input Ventilation for homes with lofts



AIREPOD

MVHR



MEV

Mechanical Extract Ventilation



The FLATMASTER Range



FOR PROPERTIES WITHOUT LOFT SPACE

Low cost ventilation for properties with no loft space. The unit is designed to take fresh air from outside, filter it and discharge the clean air into the central hallway via a ducting system.

FLATMASTER

The dwelling's internal air discharge grille is usually installed at a high level in a central location within the hallway, although discharging the air down the length of the hallway (away from the front door) should also prove acceptable. Unit performance may be enhanced if an existing heat source can warm the discharged air e.g. by locating the discharge grille above a radiator.

FLAT2000L/FLAT2000R

The unit is designed to take fresh air from outside, filter it and discharge the clean air into the central hallway via a ducting system. The dwelling's internal discharge grille is usually installed at a high level in a central hallway, although discharging the air down the length of the hallway (away from the front door), should also prove acceptable.

Additional heat when required

The FLAT2000L and FLAT2000R units come with an integral heater which tempers the air brought in from outside the property, after it has been filtered. This is an automatic function based on a set point which is triggered by the outside temperature.



Technical



DIMENSIONS (mm) & UNIT WEIGHT

WEIGHT: Flatmaster: 4.7kg FLAT2000L/FLAT2000R 2000: 5.2kg

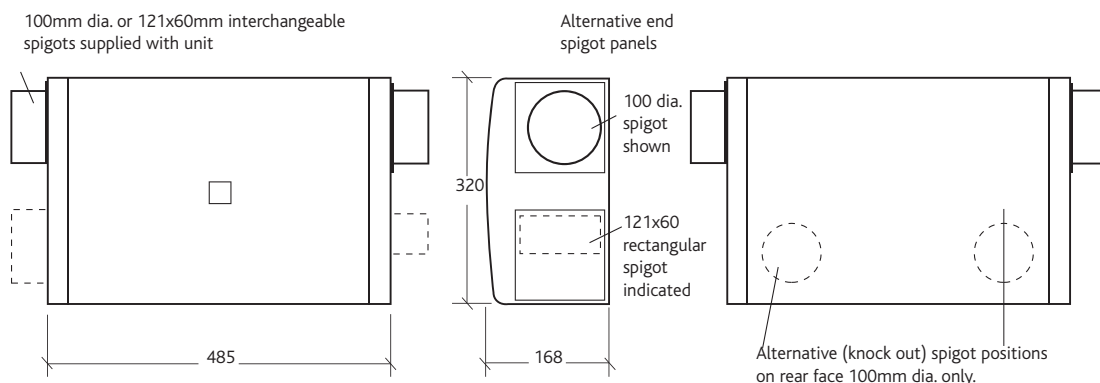

Typical Installation

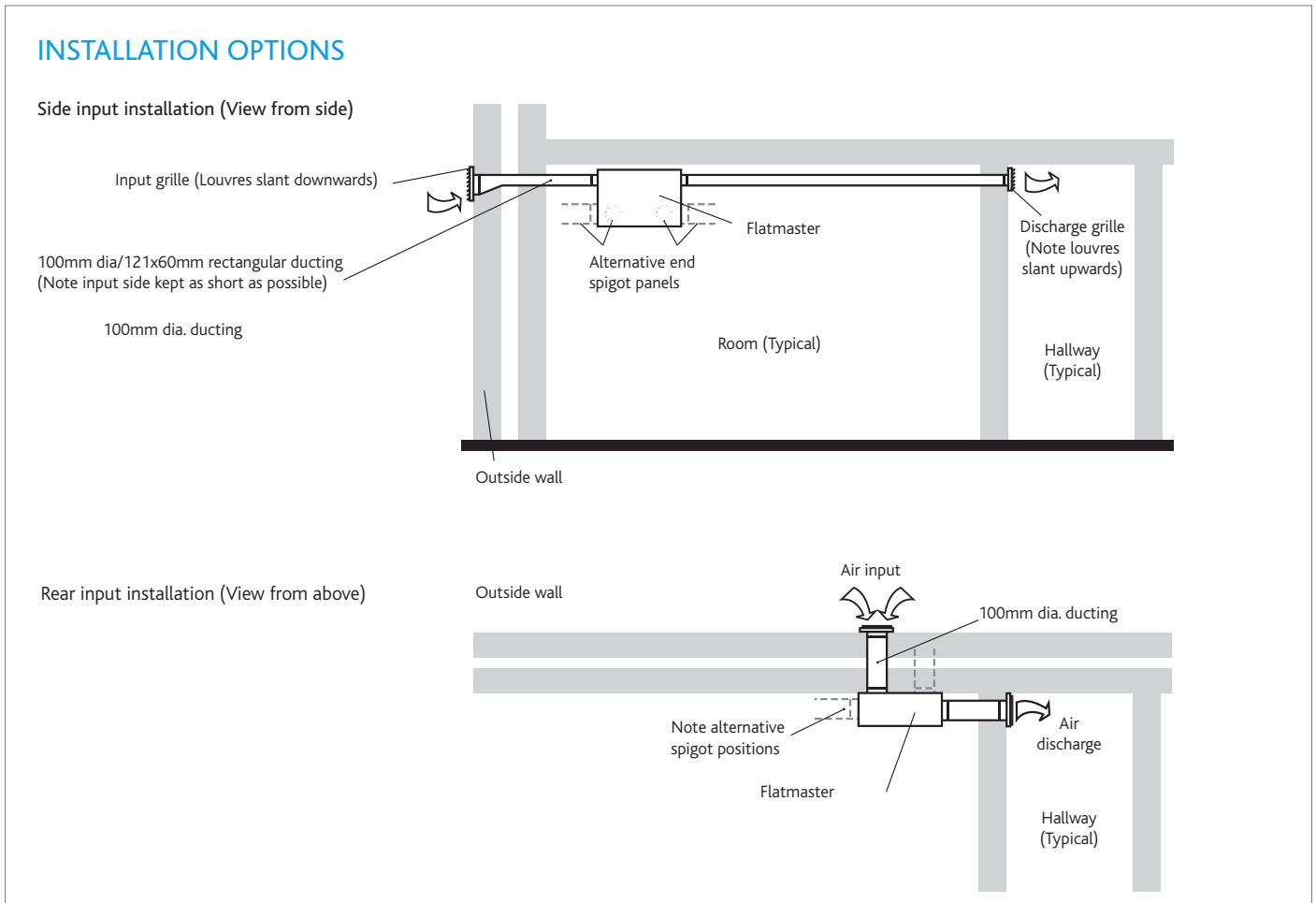

(If the heater option is required, the wiring should be connected to the appropriate terminal on the PCB).

Electrical Details

	Voltage	Consumption
FLATMASTER	230V 1ph 50Hz	Speed 1 3.1W(max)
		Speed 2 5.7W(max)
		Speed 3 9.4W(max)
FLAT2000L/FLAT2000R	230V 1ph 50Hz	Heater 300W(max)

Wiring

Please note the electrical connections to the unit should be carried out by a qualified electrician.

The unit should be wired in accordance with current IEE regulations.

A remote boost switch comes as standard with the FLAT2000L and FLAT2000R models. This must be wired directly in to the unit and can be used to control the fan with the choice of "Normal" or "Boost" functionality.

Consultants Specification

FLATMASTER

The unit casing shall be manufactured from flame retardant V0 rated ABS polymer and thermally insulated pre-coated mild steel. A washable flame retardant filter of G3 grade (with 1-2 year typical maintenance period) shall be fitted, which may be accessed via the easily removable front cover.

The unit shall incorporate an injection moulded radial bladed centrifugal impeller. The impeller shall be driven by a high efficiency, reversible brushless DC motor fitted with steel, self-lubricating bearings and locked rotor protection.

The unit shall have a maximum power consumption of 0.4w/l/s. The unit shall be highly adaptable for ease of installation, allowing circular or rectangular duct connections and air entry from side or rear of the case at high or low level.

A selection of spigots enabling connection to 100mm circular or 121x60mm rectangular distribution ductwork, without the use of transformation sections, shall be provided. Ducting and grilles shall be supplied separately.

The unit shall be offered with a 5 year warranty; 1 year parts and labour, remaining years parts only. This warranty is void if the equipment is modified without authorisation, is incorrectly applied, misused, disassembled or not installed, commissioned and maintained in accordance with the details contained in the I&M manual and general good practice.

FLAT2000L/FLAT2000R

See FLATMASTER specification.

The unit shall have a maximum power consumption of 1.1w/l/s; excluding power consumed by integral heating element.

FLATMASTER PIV Product Selector

Page No.	18	18
Feature	FLATMASTER	FLAT2000L/FLAT2000R
For properties without lofts		
Integral heater		
Manual boost switch provided – when additional ventilation is required, i.e. cooking odours		
Controls/commissioning at unit		
5 year warranty		



