

SINGLE-ROOM THROUGH-THE-WALL VENTILATOR



Fresher 50

EN

USER'S MANUAL

CONTENTS

Safety requirements.....	2
Purpose.....	4
Delivery set.....	4
Designation key.....	4
Technical data.....	5
Design and operating principle	6
Mounting and set-up.....	8
Connection to power mains	11
Technical maintenance.....	14
Troubleshooting.....	16
Storage and transportation regulations.....	16
Manufacturer's warranty	17
Certificate of acceptance.....	19
Seller information.....	19
Installation certificate.....	19
Warranty card.....	19

This user's manual is a main operating document intended for technical, maintenance, and operating staff.

The manual contains information about purpose, technical details, operating principle, design, and installation of the Fresher 50 (L) (M) unit and all its modifications.

Technical and maintenance staff must have theoretical and practical training in the field of ventilation systems and should be able to work in accordance with workplace safety rules as well as construction norms and standards applicable in the territory of the country.

SAFETY REQUIREMENTS

This unit is not intended for use by persons (including children) with reduced physical, sensory or mental capabilities, or lack of experience and knowledge, unless they have been given supervision or instruction concerning use of the unit by a person responsible for their safety. Children should be supervised to ensure that they do not play with the unit.

This appliance can be used by children aged from 8 years and above and persons with reduced physical, sensory or mental capabilities or lack of experience and knowledge if they have been given supervision or instruction concerning use of the appliance in a safe way and understand the hazards involved.

Cleaning and user maintenance shall not be made by children without supervision.

Children shall not play with the appliance. The appliance must only be supplied at safety extra low voltage corresponding to the marking on the appliance.

The appliance must only be supplied at safety extra low voltage corresponding to the marking on the appliance.

Connection to the mains must be made through a disconnecting device, which is integrated into the fixed wiring system in accordance with the wiring rules for design of electrical units, and has a contact separation in all poles that allows for full disconnection under overvoltage category III conditions.

If the supply cord is damaged, it must be replaced by the manufacturer, its service agent, or similarly qualified persons in order to avoid a safety hazard.

Ensure that the unit is switched off from the supply mains before removing the guard.

Precautions must be taken to avoid the back-flow of gases into the room from the open flue of gas or other fuel-burning appliances.

All operations described in this manual must be performed by qualified personnel only, properly trained and qualified to install, make electrical connections and maintain ventilation units.

Do not attempt to install the product, connect it to the mains, or perform maintenance yourself. This is unsafe and impossible without special knowledge.

Disconnect the power supply prior to any operations with the unit.

All user's manual requirements as well as the provisions of all the applicable local and national construction, electrical, and technical norms and standards must be observed when installing and operating the unit.

Disconnect the unit from the power supply prior to any connection, servicing, maintenance, and repair operations.

Only qualified electricians with a work permit for electrical units up to 1000 V are allowed for installation. The present user's manual should be carefully read before beginning works.

Check the unit for any visible damage of the impeller, the casing, and the grille before starting installation. The casing internals must be free of any foreign objects that can damage the impeller blades.

While mounting the unit, avoid compression of the casing! Deformation of the casing may result in motor jam and excessive noise.

Misuse of the unit and any unauthorised modifications are not allowed.

Do not expose the unit to adverse atmospheric agents (rain, sun, etc.).

Transported air must not contain any dust or other solid impurities, sticky substances, or fibrous materials.

Do not use the unit in a hazardous or explosive environment containing spirits, gasoline, insecticides, etc.

Do not close or block the intake or extract vents in order to ensure the efficient air flow.

Do not sit on the unit and do not put objects on it.

The information in this user's manual was correct at the time of the document's preparation.

The Company reserves the right to modify the technical characteristics, design, or configuration of its products at any time in order to incorporate the latest technological developments.

Never touch the unit with wet or damp hands.

Never touch the unit when barefoot.

BEFORE INSTALLING ADDITIONAL EXTERNAL DEVICES, READ THE RELEVANT USER MANUALS.

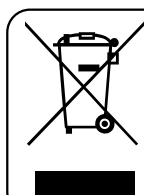

THE PRODUCT MUST BE DISPOSED SEPARATELY AT THE END OF ITS SERVICE LIFE.

DO NOT DISPOSE THE UNIT AS UNSORTED DOMESTIC WASTE.

PURPOSE

The unit is designed to ensure continuous mechanical air supply in houses, offices, hotels, cafés, conference halls and other utility and public spaces. The ventilator is equipped with a coarse and a fine filter, used for fresh filtered air supply to premises. The ventilator is designed for wall flush mounting.

DELIVERY SET

Name	Number
Indoor assembly unit of the ventilator	1 pc.
Air duct	1 pc.
Sound-absorbing material	1 pc.
Cartridge assembly	1 pc.
Outer ventilation hood	1 pc.
Remote control (optional)	1 pc.
Cardboard mounting plate	1 pc.
Mounting kit	2 packages
Foam wedges	1 kit
User's manual	1 pc.
Mounting hood installation instruction	1 pc.
Packing box	1 pc.

DESIGNATION KEY

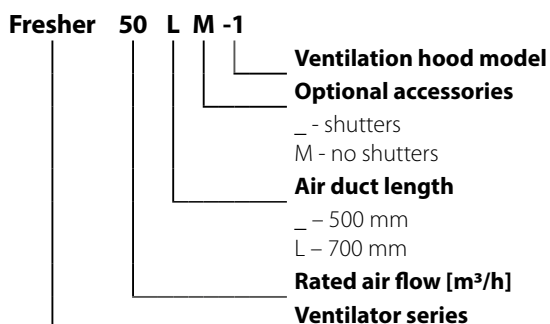

TECHNICAL DATA

The temperature in the room where the indoor unit of the ventilator is installed must be in the range from +1 °C to +40 °C with relative air humidity up to 95 % (no condensation buildup).

If the conditions of use of the ventilator are outside the specified limits, turn off the ventilator.

Provide fresh air with open windows.

The temperature of the transported air should be in the range from -30 °C to +50 °C.

The unit is rated as a class II electric appliance.

Ingress protection rating against access to hazardous parts and water ingress is IP24.

The ventilator design is regularly improved, so some models may slightly differ from those ones described herein.

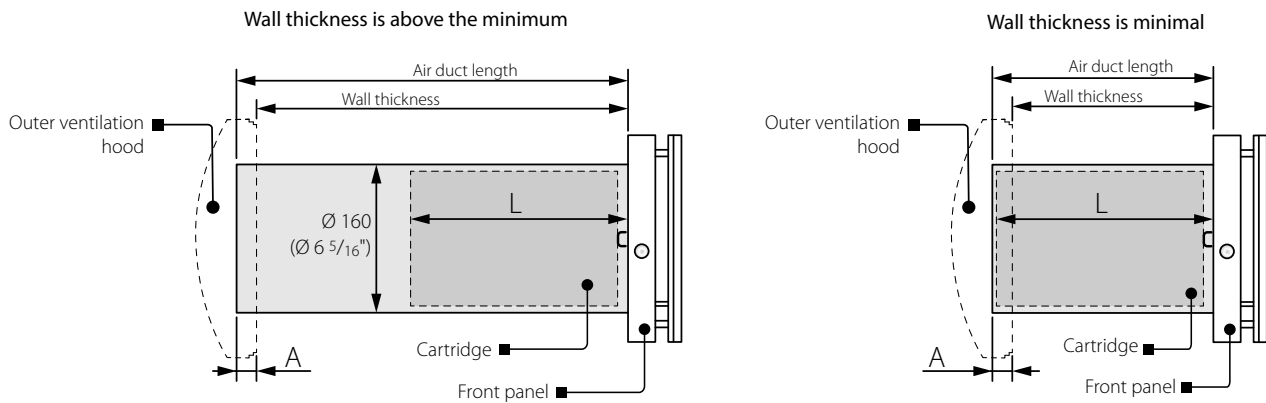

The air duct length depends on the unit model, refer to the Designation Key.

The supplied ventilation hood model depends on the ventilator model.

The overall dimensions of the outer ventilation hood, the required outside protrusion length of the air duct A and the mounting sequence of the hood are stated in its mounting instruction.

Technical specifications of the particular model are indicated on the unit casing.



OVERALL DIMENSIONS OF THE INDOOR UNIT [MM]

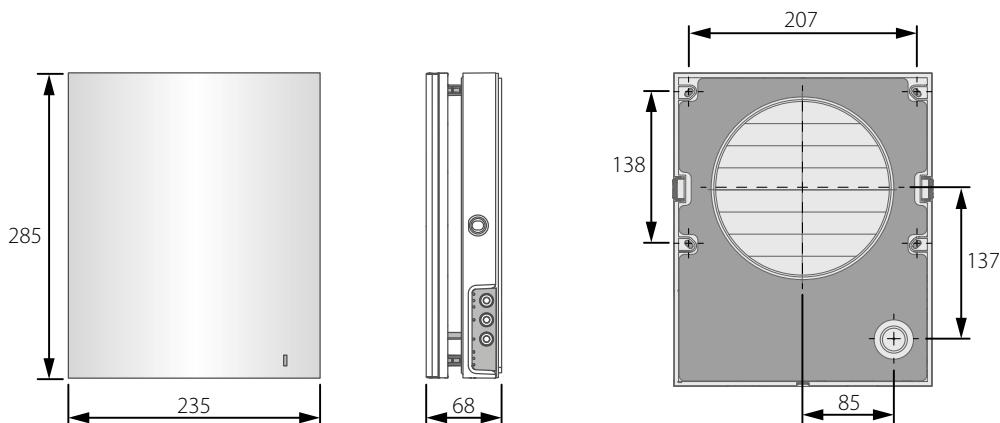

DESIGN AND OPERATING PRINCIPLE

The ventilator consists of an indoor unit with a decorative front panel, a cartridge, an air duct with a sound absorbing layer and an outer ventilation hood.

The cartridge is a basic functioning part of the ventilator. The cartridge consists of a fan and two filters that ensure coarse and fine air filtration and prevent ingress of dust and foreign objects into the fan.

The indoor unit is equipped with protection shutters (only for standard ventilator models, see section Designation key) that close during the ventilator standstill and prevent air backdraft.

The outer ventilation hood is used to prevent direct ingress of water and other objects to the ventilator.

VENTILATOR DESIGN

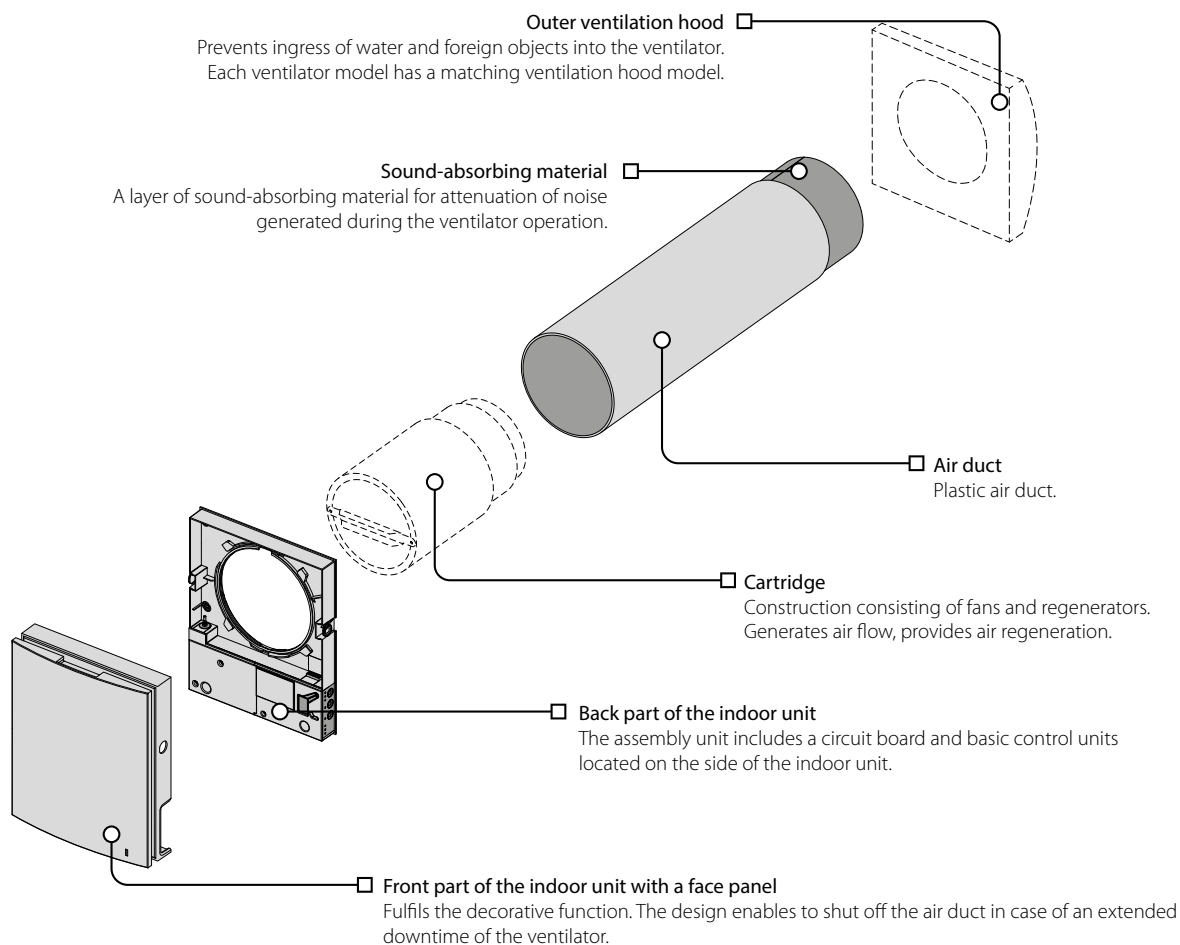

OPERATING LOGIC OF THE AUTOMATIC SHUTTERS

The indoor unit is equipped with automatic shutters. During the ventilator operation the automatic shutters are opened and let the air flow freely through the ventilator. The automatic shutters are closed for 2 minutes at the ventilator shut down.

WARNING! In case of supplying power to the ventilator when the frontal part of the indoor unit is removed, no power is supplied to the actuator and its rod is not lifted to avoid damage. After installing the front part of the indoor unit into place, the louver actuator will start operating normally.

The shutters are closed

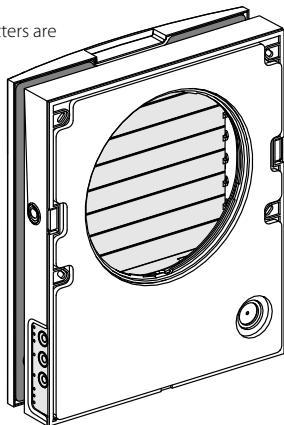

The shutters are opened

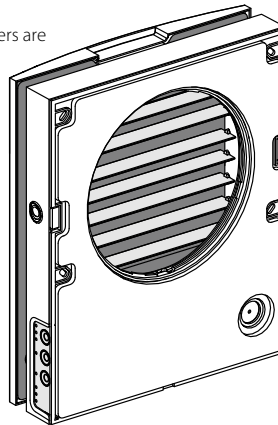

MOUNTING AND SET-UP

 **READ THE USER'S MANUAL BEFORE INSTALLING THE UNIT.**

 **DO NOT BLOCK THE AIR DUCT OF THE INSTALLED VENTILATOR WITH DUST ACCUMULATING MATERIALS, SUCH AS CURTAINS, CLOTH SHUTTERS, ETC. AS IT PREVENTS AIR CIRCULATION IN THE ROOM.**

1. Prepare a round core hole in the outer wall. The hole size is shown in the figure below. While preparing core holes it is recommended to make preparations for layout of the power cable and other required cables.

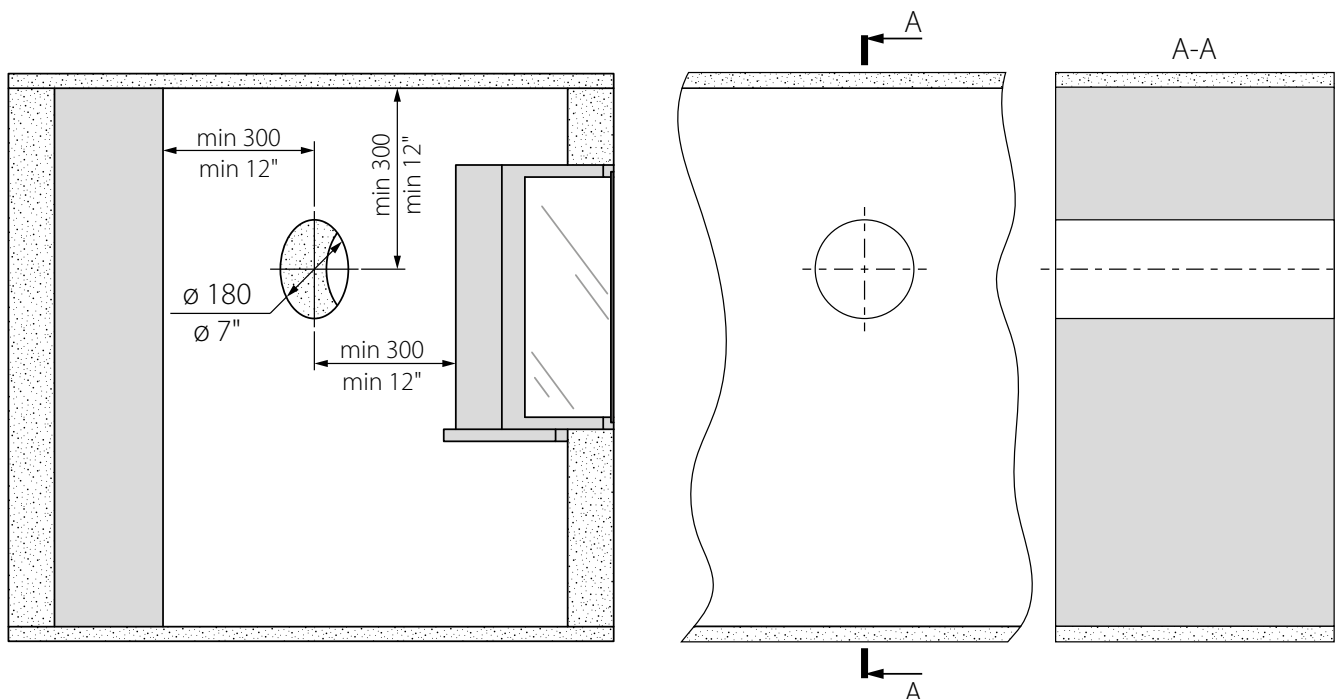

2. Install the air duct in the wall in such a way so it protrudes from the wall surface for maximum 3 mm or is flush with the wall. Fix it with mounting foam.

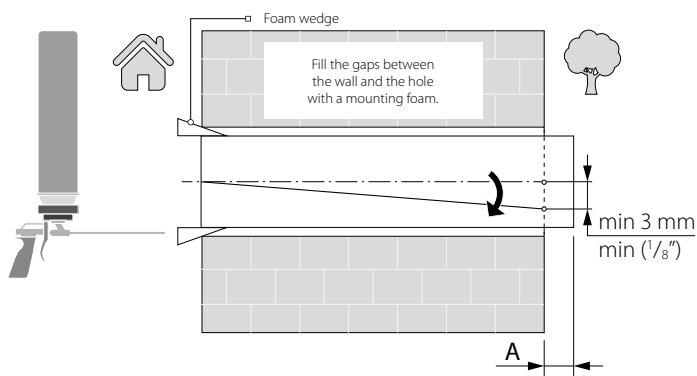

Install the air duct with the minimum slope 3 mm downwards. On the outer wall side the air duct end must protrude to a distance that enables installation of the outer ventilation hood. The distance A is stated in the installation instruction for the ventilation hood.

3. Stick the delivered cardboard master plate on the indoor wall using a mounting tape. The large opening in the master plate must be axially aligned with the air duct. For aligning the master plate with respect to the horizon line it is recommended to use a builder's level. Then mark the fastening holes for installation of the supplied dowels and drill the holes to a required depth. Route the power cable from the wall outside through the specially marked opening on the master plate.

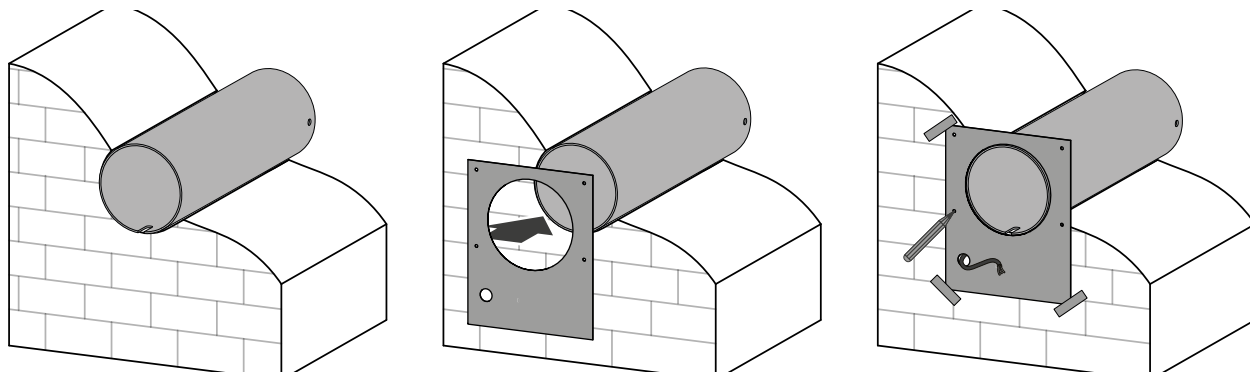

4. Unlatch and detach the front part of the indoor unit from its back part.

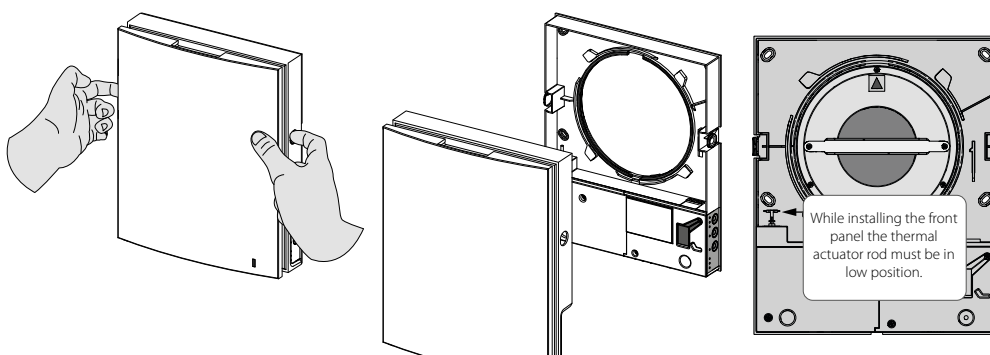

5. Fix the back part of the indoor unit on the wall with the screws supplied with the mounting kit of the ventilator. Remove the two retaining screws from the left transparent cover to enable access to the terminals.

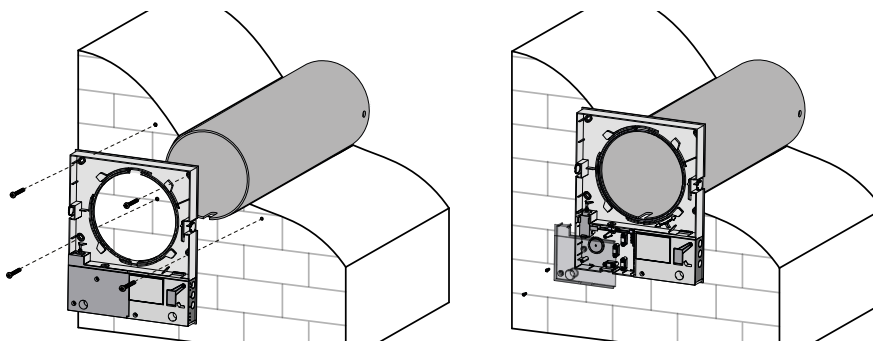

6. Route the power cable as figured below and connect the ventilator to power mains in compliance with the external wiring diagram, refer to page 11.

Fix the power cable and the signal cables with cable clamps. After completion of the electrical connection re-install the transparent cover in site.

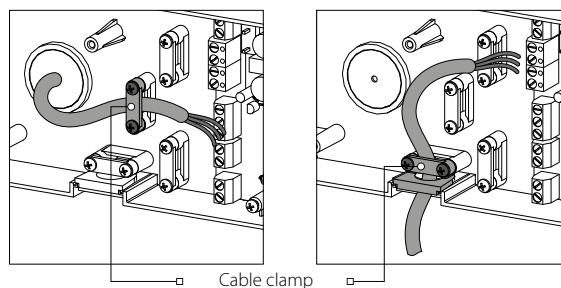

7. Install the cartridge into the air duct as figured below. The pointer must be directed upwards. Then fix the wire with the protruding clamp and connect the connector to the circuit board.

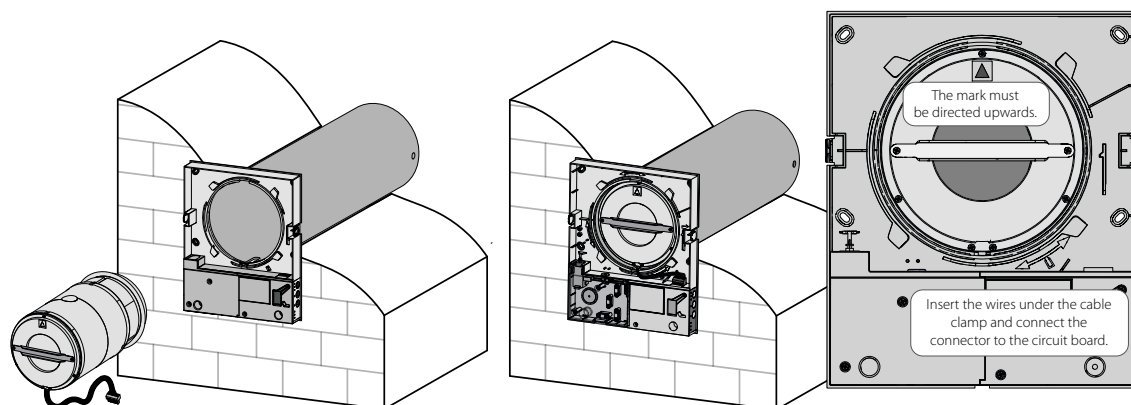

8. Install the front part of the indoor unit. The thermal actuator rod must be in lower position when installing the front panel, as shown in the figure in Section 4 on page 9.

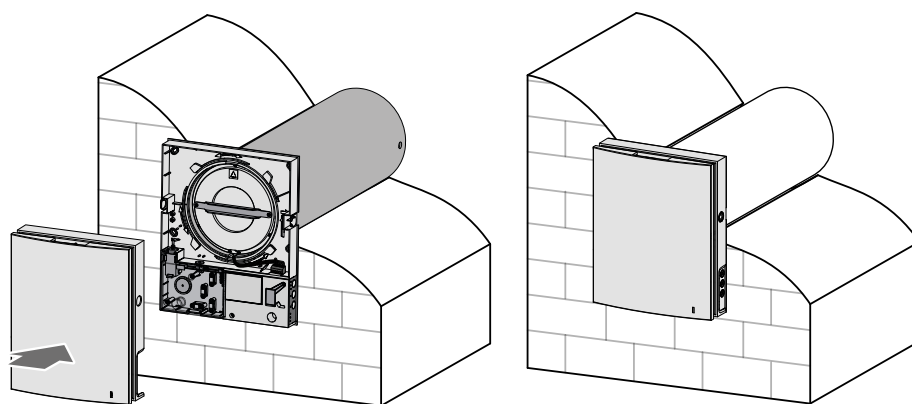

9. Insert the sound absorbing layer into the air duct from the outside. Roll the layer of the sound absorbing material to match the air duct diameter. The protecting paper layer must be outside. Insert the sound absorbing roll into the cartridge against stop. Make a mark at the end of the air duct, remove the material and cut the roll as marked. Insert the ready sound absorbing roll into the air duct.

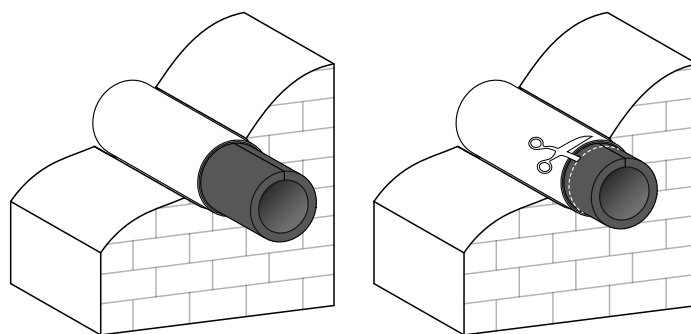

10. Install the outer ventilation hood. For this, see the user's manual for the hood.

CONNECTION TO POWER MAINS



POWER OFF THE POWER SUPPLY PRIOR TO ANY OPERATIONS WITH THE UNIT.

THE UNIT MUST BE CONNECTED TO POWER SUPPLY BY A QUALIFIED ELECTRICIAN.

THE RATED ELECTRICAL PARAMETERS OF THE UNIT ARE GIVEN ON THE MANUFACTURER'S LABEL.

The ventilator is rated for connection to single-phase AC 100-240 V 50/60 Hz power mains. Connect the ventilator to power mains through an automatic circuit breaker with magnetic trip integrated into the home wiring system. The tripping current of the circuit breaker is selected based on the electrical characteristics shown on the label of the fan casing. For electric installations use insulated, durable and heat-resistant conductors (cables, wires) with the minimum cross section of 0.5 up to 0.75 mm² for a power cable and 0.25 mm² for signal cables. The cable cross-section is given for reference only. The actual conductor cross-section selection must be based on its type, the maximum permissible heating, insulation, length and installation method. Use copper wires for all the electric connections! Connect the ventilator to power mains in compliance with the wiring diagram.

The ventilator design enables connecting any external controls with a normally opened contact (NO-contact), such as an external CO₂ sensor, humidity sensor, relay switch, etc. When the normally open contact of the external device is closed, the ventilator goes to a maximum speed. The ventilators can be connected in series and in parallel with a central control by the master ventilator. In case of in series or in parallel connection of several ventilators power is supplied either from a previous ventilator or from power mains.

EXTERNAL CONNECTIONS DIAGRAM

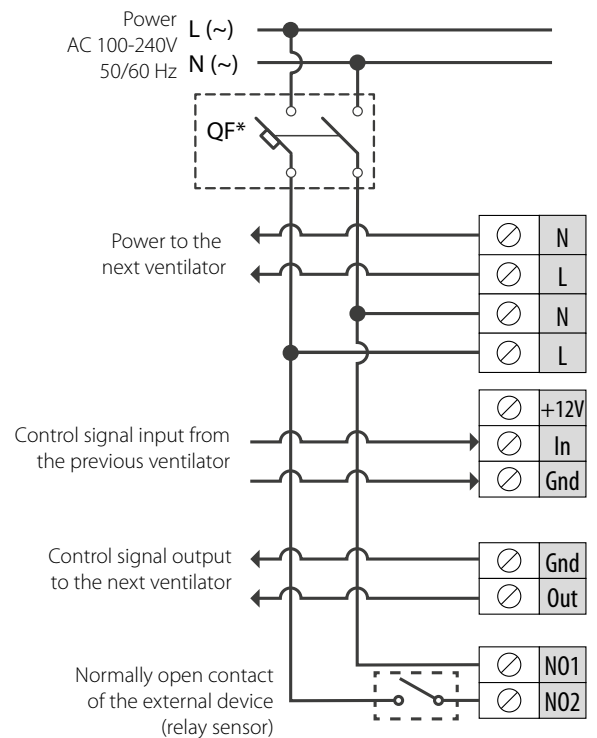

WIRING DIAGRAM FOR IN SERIES CONNECTION

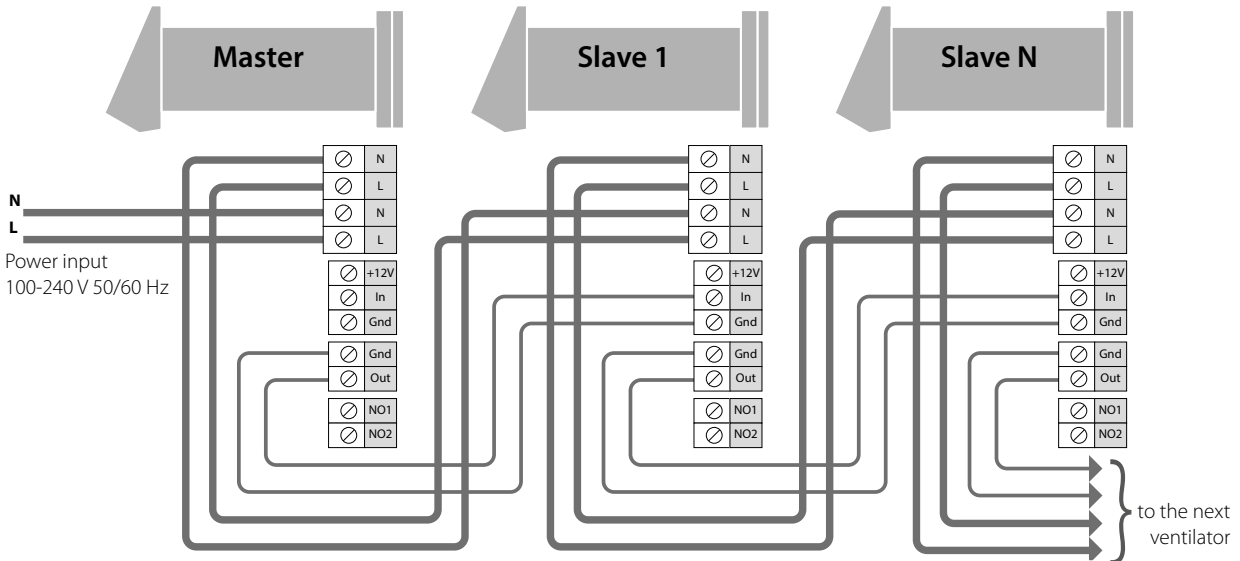

WIRING DIAGRAM FOR IN PARALLEL CONNECTION

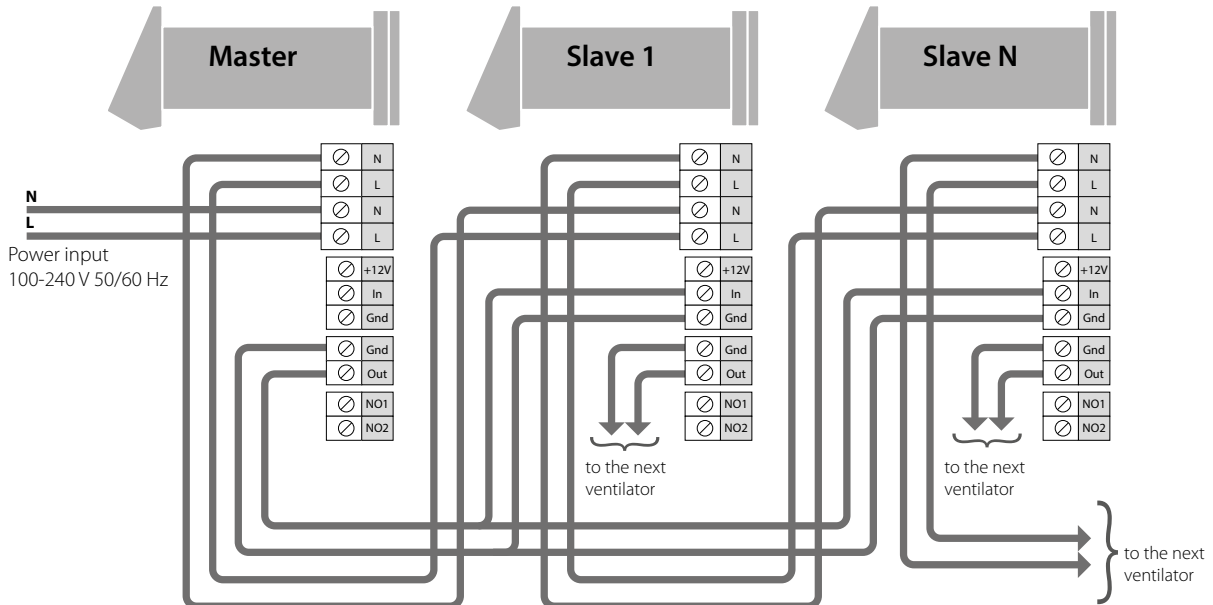

VENTILATOR CONTROL

The ventilator can be operated with the remote control or the control buttons on the side part of the indoor unit, as figured below. In case of in series or in parallel connection, the signal from a control unit is received by the first ventilator (Master) only.

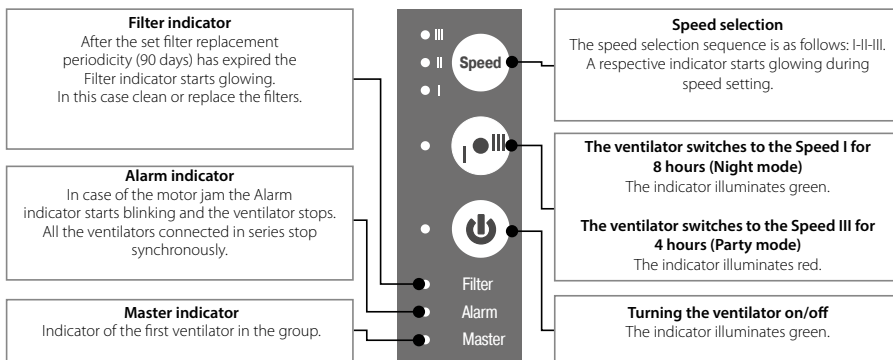

Buttons on the ventilator casing



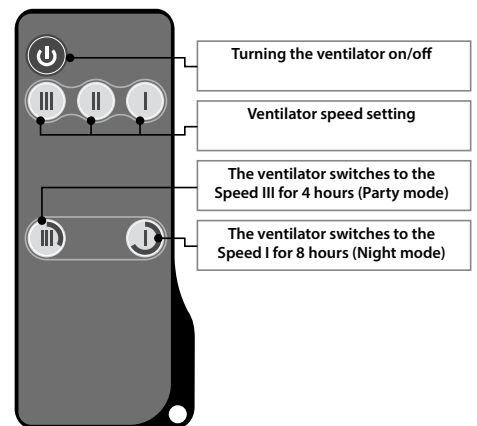



Buttons on the remote control



VENTILATOR CONTROL WITH THE BUTTONS ON THE INDOOR UNIT

	The speed selection sequence is as follows: I-II-III. All the connected in series ventilators synchronise their speed with the first ventilator in the group.
	Timer button (cyclical switch between modes): 8 hours at Speed I (Night mode). When this mode is activated, the indicator lights green. 4 hours at Speed III (Party mode). When this mode is activated, the indicator lights red. Upon expiration of the set time period the ventilator reverts to a pre-set speed. Press any button of the manual speed setting to deactivate the timer.
	Turning the ventilator on/off.
Filter	Contamination indicator of filters. 90 days after installation of the cartridge the filter replacement indicator starts glowing. In this case, clean or replace the filters (see the "Technical maintenance" section). In case of in-series connection, the first ventilator indicator has a steady glow and the indicator of the ventilator requiring filter replacement blinks.
Alarm	Motor jam indicator. In case of the motor jam, the Alarm indicator starts blinking and the ventilator stops. All the connected in series ventilators also stop synchronously. When connected in series, the indicators of the first ventilators signal with a steady light and the indicator of the ventilator in which the motor is jammed blinks.
Master	Indicator of the first ventilator in the group.

REMOTE CONTROL OF THE VENTILATOR

	Turning the ventilator on/off.
	Ventilator speed selection: Speed III-II-I respectively.
	Timer buttons:  Party mode: 4 hours on the third speed  Night mode: 8 hours on the first speed Upon expiration of the set time period the ventilator reverts to a pre-set speed. Press any button of the manual speed setting to deactivate the timer.

AIR DUCT CLOSING

Press the front panel to close the air duct. The fan turns off automatically.

To open the air duct, pull the front panel while holding the special recesses. The fan starts operating according to the actual speed setting.

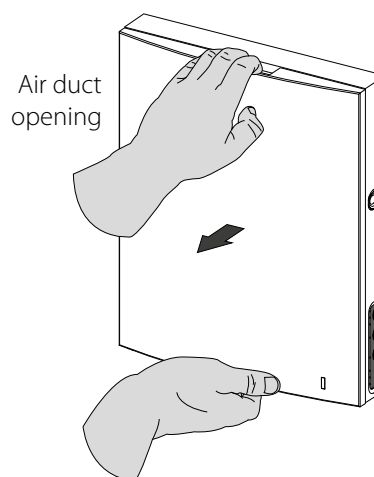
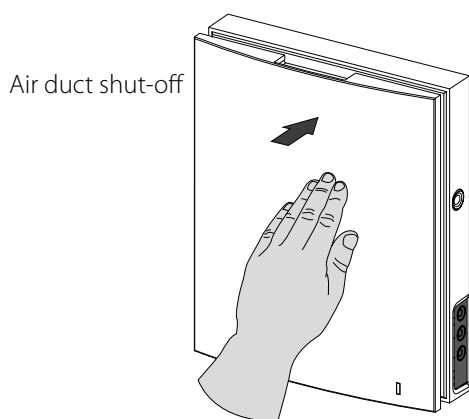

The front panel incorporates an operating LED indicator. During the dark time the indicator light intensity drops down.

TECHNICAL MAINTENANCE

Maintenance of the ventilator means regular cleaning of the ventilator surfaces of dust and cleaning and/or replacement of the filters. To access the basic assembly units, follow the steps:

1. Press the latches on the side of the indoor control unit to take off the front part.

Please make sure the louver actuator rod is in lower position during re-installation of the front panel. If the rod is up, please wait for about 2 minutes until it goes down.

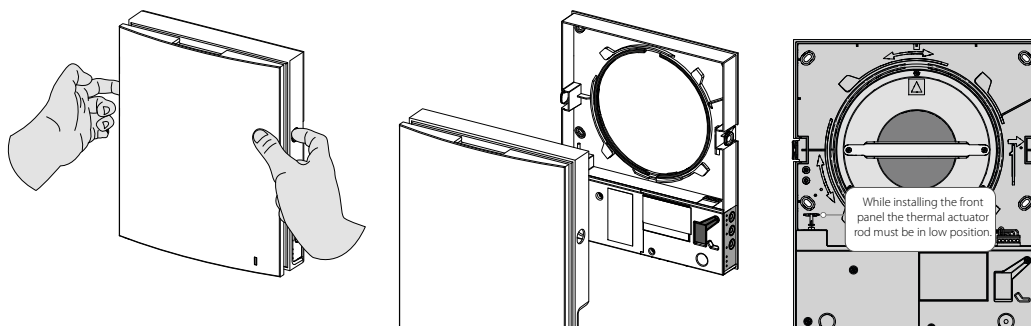

2. Disconnect the connector from the circuit board. Do not remove the connector by pulling the wires. Use a flat screwdriver to uplift it if required.

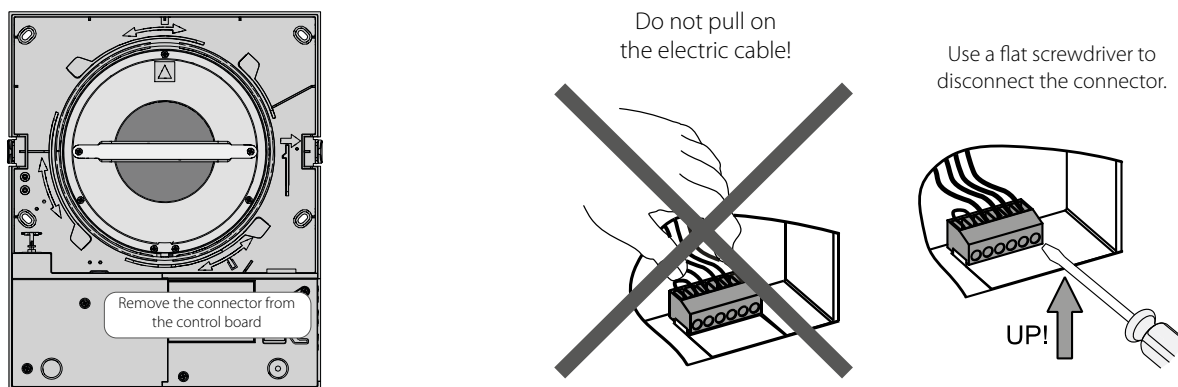

3. Pull the handle to remove the cartridge from the air duct. Remove the filters from the cartridge.

To remove the fine filter, undo 5 self-tapping screws that secure it, remove the cover and pull the filter out of the cartridge. A new fine filter should be installed in the reverse order.

The coarse filter is removed by pulling out of the grooves.

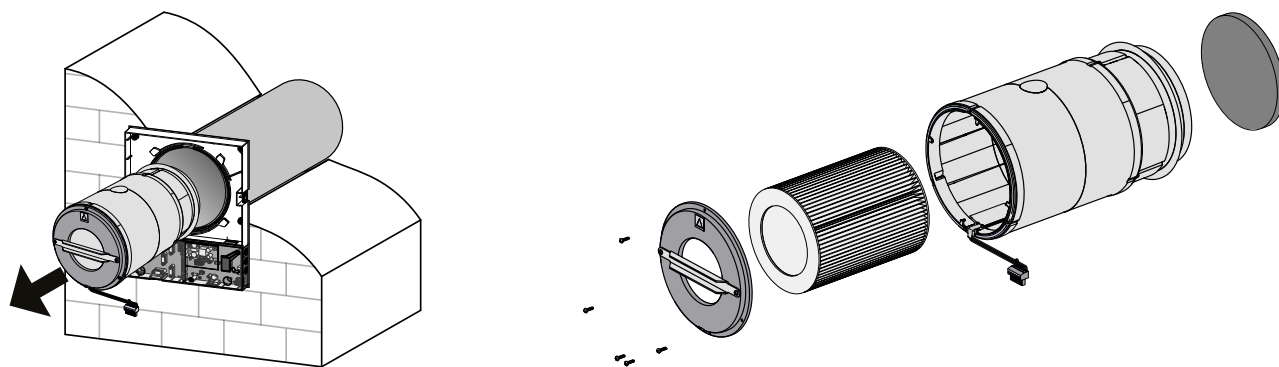

The fine filter is maintenance-free and must be replaced after 90 days of non-stop operation of the unit. Clean the coarse filter as it gets clogged, but not less than once in three months.

- After the set filter replacement periodicity (90 days) has expired the Filter indicator starts glowing.
- The filter timer is reset once the cartridge socket is disconnected from the circuit board.
- Wash the filter and let it get dry. Install a dry filter in the air duct.
- Vacuum cleaning is allowed.
- The filter rated service life is 3 years.
- For new filters contact the Seller.

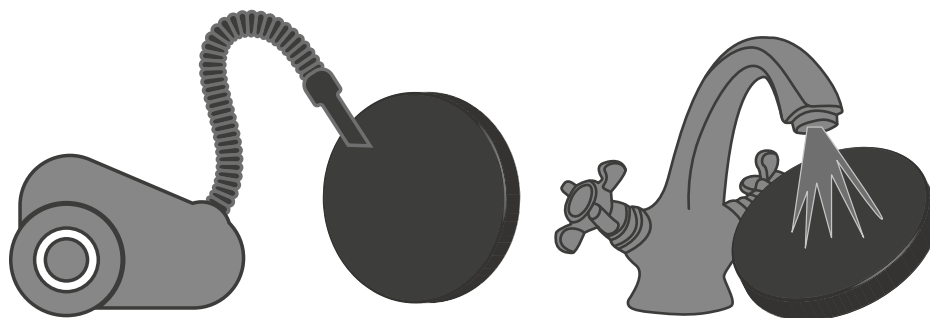

4. Replacement of the remote control battery (if necessary).

In case of a long operation of the remote control, the battery must be replaced.

No response of the unit for pressing the remote control buttons indicates the need to replace the battery.

The battery type is CR2025.

Remove the holder with the battery from the lower part of the remote control.

Replace the battery and install the holder with a new battery back to the remote control.

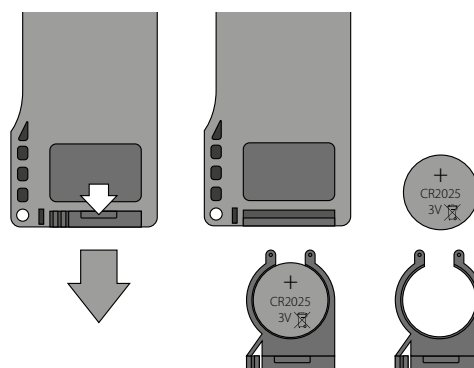

TROUBLESHOOTING

POSSIBLE REASONS AND TROUBLESHOOTING

Problem	Possible reasons	Troubleshooting
When switching on the ventilator, the fan does not start.	No power supply.	Make sure the power supply line is connected correctly, otherwise troubleshoot the connection error.
	The motor is jammed, the impeller blades are soiled.	Turn the ventilator off. Troubleshoot the motor jam and impeller clogging. Clean the blades. Restart the ventilator.
Circuit breaker tripping during the ventilation unit start-up.	Overcurrent as a result of short circuit in the electric line.	Turn the ventilator off. Contact the Seller for further information.
Low air flow.	Low set fan speed.	Set higher speed.
	The filters, the fan or the regenerator are clogged.	Clean or replace the filter. Clean the fan and the heat exchanger.
Noise, vibration.	The impeller is clogged.	Clean the impeller.
	Loose screw connection of the unit casing or the outer ventilation hood.	Tighten the screws of the ventilator or the outer ventilation hood.

STORAGE AND TRANSPORTATION REGULATIONS

- Store the unit in the manufacturer's original packaging box in a dry closed ventilated premise with temperature range from +5 °C to + 40 °C and relative humidity up to 70 %.
- Storage environment must not contain aggressive vapors and chemical mixtures provoking corrosion, insulation, and sealing deformation.
- Use suitable hoist machinery for handling and storage operations to prevent possible damage to the unit.
- Follow the handling requirements applicable for the particular type of cargo.
- The unit can be carried in the original packaging by any mode of transport provided proper protection against precipitation and mechanical damage. The unit must be transported only in the working position.
- Avoid sharp blows, scratches, or rough handling during loading and unloading.
- Prior to the initial power-up after transportation at low temperatures, allow the unit to warm up at operating temperature for at least 3-4 hours.

MANUFACTURER'S WARRANTY

The product is in compliance with EU norms and standards on low voltage guidelines and electromagnetic compatibility. We hereby declare that the product complies with the provisions of Electromagnetic Compatibility (EMC) Directive 2014/30/EU of the European Parliament and of the Council, Low Voltage Directive (LVD) 2014/35/EU of the European Parliament and of the Council and CE-marking Council Directive 93/68/EEC. This certificate is issued following test carried out on samples of the product referred to above.

The manufacturer hereby warrants normal operation of the unit for 24 months after the retail sale date provided the user's observance of the transportation, storage, installation, and operation regulations. Should any malfunctions occur in the course of the unit operation through the Manufacturer's fault during the guaranteed period of operation, the user is entitled to get all the faults eliminated by the manufacturer by means of warranty repair at the factory free of charge. The warranty repair includes work specific to elimination of faults in the unit operation to ensure its intended use by the user within the guaranteed period of operation. The faults are eliminated by means of replacement or repair of the unit components or a specific part of such unit component.

The warranty repair does not include:

- routine technical maintenance
- unit installation/dismantling
- unit setup

To benefit from warranty repair, the user must provide the unit, the user's manual with the purchase date stamp, and the payment paperwork certifying the purchase. The unit model must comply with the one stated in the user's manual. Contact the Seller for warranty service.

The manufacturer's warranty does not apply to the following cases:

- User's failure to submit the unit with the entire delivery package as stated in the user's manual including submission with missing component parts previously dismantled by the user.
- Mismatch of the unit model and the brand name with the information stated on the unit packaging and in the user's manual.
- User's failure to ensure timely technical maintenance of the unit.
- External damage to the unit casing (excluding external modifications as required for installation) and internal components caused by the user.
- Redesign or engineering changes to the unit.
- Replacement and use of any assemblies, parts and components not approved by the manufacturer.
- Unit misuse.
- Violation of the unit installation regulations by the user.
- Violation of the unit control regulations by the user.
- Unit connection to power mains with a voltage different from the one stated in the user's manual.
- Unit breakdown due to voltage surges in power mains.
- Discretionary repair of the unit by the user.
- Unit repair by any persons without the manufacturer's authorization.
- Expiration of the unit warranty period.
- Violation of the unit transportation regulations by the user.
- Violation of the unit storage regulations by the user.
- Wrongful actions against the unit committed by third parties.
- Unit breakdown due to circumstances of insuperable force (fire, flood, earthquake, war, hostilities of any kind, blockades).
- Missing seals if provided by the user's manual.
- Failure to submit the user's manual with the unit purchase date stamp.
- Missing payment paperwork certifying the unit purchase.



FOLLOWING THE REGULATIONS STIPULATED HEREIN WILL ENSURE A LONG AND TROUBLE-FREE OPERATION OF THE UNIT.



USER'S WARRANTY CLAIMS SHALL BE SUBJECT TO REVIEW ONLY UPON PRESENTATION OF THE UNIT, THE PAYMENT DOCUMENT AND THE USER'S MANUAL WITH THE PURCHASE DATE STAMP.

CERTIFICATE OF ACCEPTANCE

Unit Type	Single-room through-the-wall ventilator
Model	
Serial Number	
Manufacture Date	
Quality Inspector's Stamp	

SELLER INFORMATION

Seller	
Address	
Phone Number	
E-mail	
Purchase Date	
This is to certify acceptance of the complete unit delivery with the user's manual. The warranty terms are acknowledged and accepted.	
Customer's Signature	

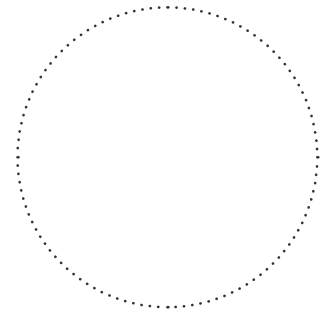

Seller's Stamp

INSTALLATION CERTIFICATE

The _____ unit is installed pursuant to the requirements stated in the present user's manual.	
Company name	
Address	
Phone Number	
Installation Technician's Full Name	
Installation Date:	Signature:
The unit has been installed in accordance with the provisions of all the applicable local and national construction, electrical and technical codes and standards. The unit operates normally as intended by the manufacturer.	
Signature:	

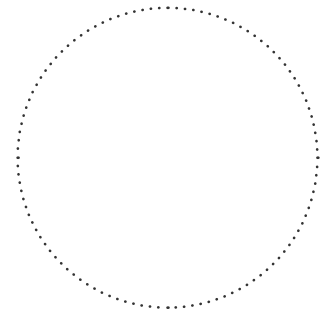

Installation Stamp

WARRANTY CARD

Unit Type	Single-room through-the-wall ventilator
Model	
Serial Number	
Manufacture Date	
Purchase Date	
Warranty Period	
Seller	

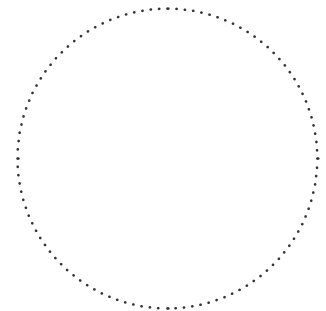

Seller's Stamp

