

Part Number: **SPDCUKITT2TPN**
 Description: **T2 SPD 3P+NPE**
 Document: **Jan2023**

3 Phase (3P+NPE) T2 Surge Protection Device (SPD) supplied complete with 32A B Curve triple pole MCB and 6mm² connecting cables.

This device must be installed and tested by a qualified electrician in accordance with the current IET Wiring Regulations BS7671.

CAUTION

WHEN CONDUCTING INSULATION RESISTANCE TESTING WITH SPD FITTED IT IS RECOMMENDED EITHER THE **EARTH CONNECTION OR THE PLUG IN CARTRIDGES ARE REMOVED.**

IF YOU DO NOT WISH TO REMOVE THE CARTRIDGES OR EARTH CONNECTION, THEN TESTING MUST BE AT A **MAXIMUM OF 250V DC.**

Before powering up the installation check all connections are TORQUED 2.5Nm. Loose connections cause fires!

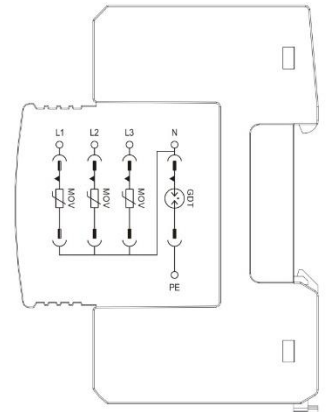
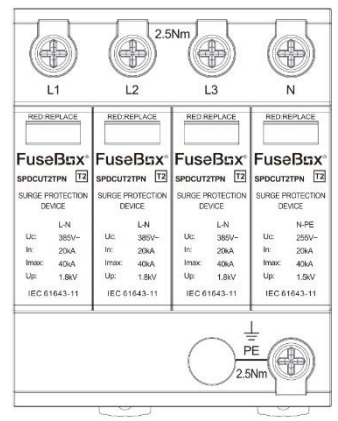
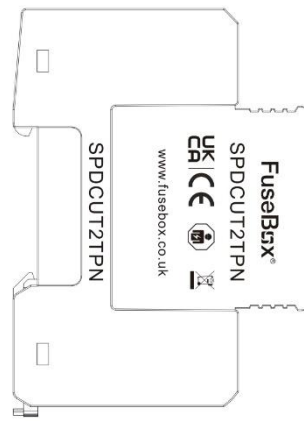

TECHNICAL (TABLE A)	
PART NUMBER	SPDCUKITT2TPN
BARCODE	5060523525096
DESCRIPTION	SURGE PROTECTION DEVICE T2 Includes 32A TP B TYPE MCB and cables (6mm ²)
WIDTH	72mm (4 module)
STANDARD	IEC/EN 61643-11
FLAG INDICATION	GREEN: GOOD RED: REPLACE
TECHNOLOGY	MOV (METAL OXIDE VARISTOR) L -PE /GDT (GAS DISCHARGE TUBE) N - PE
Nominal VOLTAGE (Un)	400V~ 50/60Hz
SYSTEM	TN-C-S, TN-S, TT
TERMINAL CAPACITY (max.)	6mm ² - 35mm ²
RECOMMENDED TORQUE	2.5Nm
DEGREE OF PROTECTION	IP20
MOUNTING	35mm DIN RAIL (to EN 60715)
MAXIMUM OPERATING VOLTAGE (Uc)	385V
RESPONSE TIME (ta)	≤100Ns
MAXIMUM BACK UP FUSE (F1)	125A fuse gG
RECOMMENDED BACKUP MCB (F2)	32A
SHORT CIRCUIT WITHSTAND (IscR)	50kA

TECHNICAL (TABLE B)		
Energy coordination with terminal equipment (≤10m)	Type 2 + Type 3	
Type	3P+NPE	
	L-N MOV (Varistors)	N-PE GDT (Spark gap)
Max. continuous operating voltage (AC) (Uc)	385V (50/60Hz)	255V (50/60Hz)
Nominal discharge current (8/20µs) L-N /N-PE (In)	20KA	20KA
Maximum Discharge Current (8/20µs) L-N/N-PE (Imax)	40KA	40KA
Voltage protection level L-N /N-PE (Up)	<1.8kV	<1.5kV
Temporary overvoltage (TOV) L-N (UT)	440V/12 min-- withstand	
Temporary overvoltage (TOV) L-N (UT)	1200V/200ms - withstand	
Operating temperature range	-40 °C +80 °C	
Material (housing)	Thermoplastic UL94 V0	
Weight (Kg)	0.4Kg	

After installation and testing of this product it is essential that the INSTRUCTION LEAFLET is available for reference.

1 **SYSTEM CONNECTION DIAGRAMS**

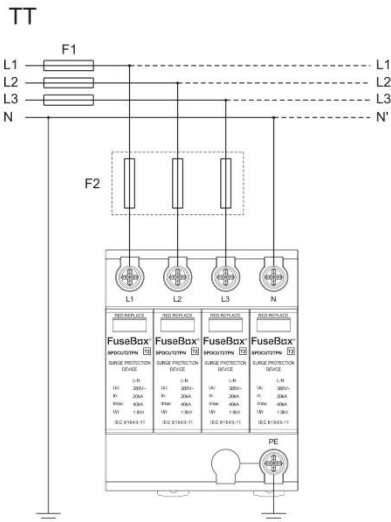
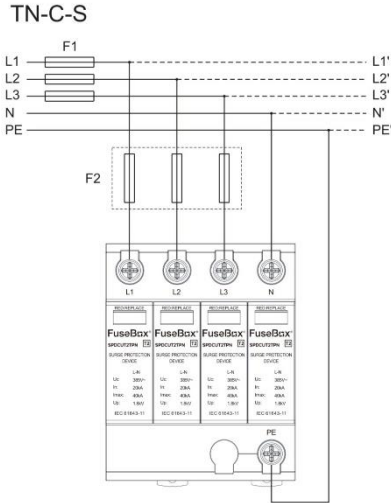

2 **TORQUE SETTING**

Before powering up the installation check all connections are TORQUED to 2.5Nm. Loose connections cause fires!

3 **FLAG INDICATOR STATUS**

- Please ensure the SPD flag indicator status is checked regularly.
- Should the indicator change to RED the module should be replaced ASAP to continue to provide surge protection.
- The SPD is in parallel to the supply so in no way affects the power to the final circuits if activated (RED).

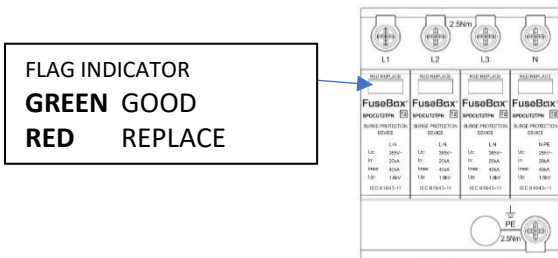

4 **SPD MODULE REPLACEMENT**

- Before changing the SPD cartridges switch OFF supply.
- The 18mm modules can be removed as shown below.
- Pull cartridge out of the holder firmly.
- When refitting module ensure it is pushed home firmly and is keyed in the slots on the base. Neutral cartridge is keyed differently.
- Once changed switch power to ON.

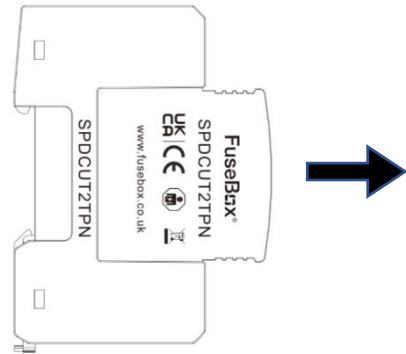

5 **INSTALLATION INTO A TPN DISTRIBUTION BOARD**

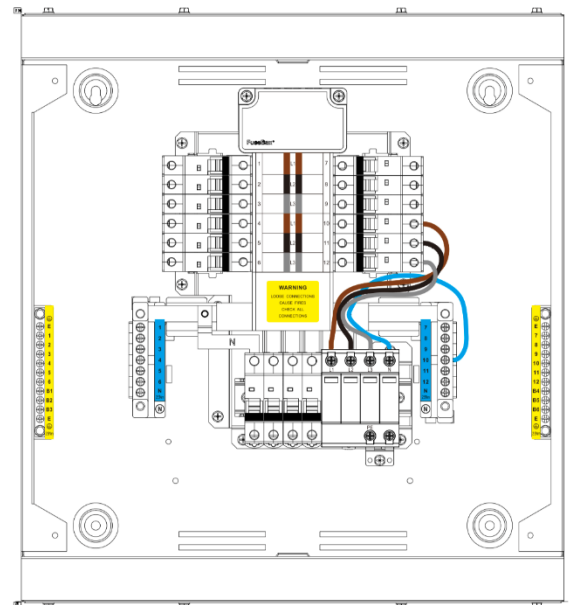

6 **ENVIRONMENT**

WASTE ELECTRICAL PRODUCTS SHOULD NOT BE DISPOSED OF IN HOUSEHOLD WASTE. CONTACT YOUR RETAILER OR LOCAL AUTHORITY FOR RECYCLING INFORMATION.

After installation and testing of this product it is essential that the INSTRUCTION LEAFLET is available for reference.

www.fusebox.co.uk



TPN DISTRIBUTION BOARD

(125A main switch fitted)

Suitable for 6kA and 10kA FuseBox devices

After installation and testing of this product it is essential that the **INSTRUCTION LEAFLET** is available for reference.

This distribution board must be installed and tested by a qualified electrician in accordance with the current IET Wiring Regulations BS7671.

Standards (TABLE 1)	
Device	Standard
Consumer Unit	EN 61439-3
Main Switch 4P	IEC EN 60947-3
RCD	IEC EN 61008-1
MCB	IEC EN 60898-1
RCBO	IEC EN 61009-1
IP RATING	IP3X
Main Switch	125A 4 pole (factory fitted)
Busbar Current Rating	125A
Busbar Rating	16kA
Voltage Rating	230/400V ~
Number of Ways (3P)	Without SPD fitted: 4,8,12,16 With SPD fitted: 3,7,11,15
Material	Steel
	1mm
	Electro galvanised steel (zinc)
Finish	RAL 9001 powder coated finish
Mounting	Keyhole fixings in all corners
Lock	Standard coin slot

Recommended Torque Settings (TABLE 2)		
Device	Max. Cable Capacity	Recommended Torque
MAIN SWITCH	50mm ²	2.5Nm
RCD	35mm ²	2.5Nm
MCB	16mm ²	2.5Nm
Earth/Neutral Terminals	25mm ²	2.5Nm

Dimensions	
Part number	Dimensions (HxWxD)mm
TPN03FBX	542 x 500 x 106
TPN04FB	542 x 500 x 106
TPN07FBX	642 x 500 x 106
TPN08FB	642 x 500 x 106
TPN11FBX	812 x 500 x 106
TPN12FB	812 x 500 x 106
TPN15FBX	992 x 500 x 106
TPN16FB	992 x 500 x 106
TPNEFB	352 x 500 x 106

TPN04FB

125A 4WAY 4P MAIN SWITCH

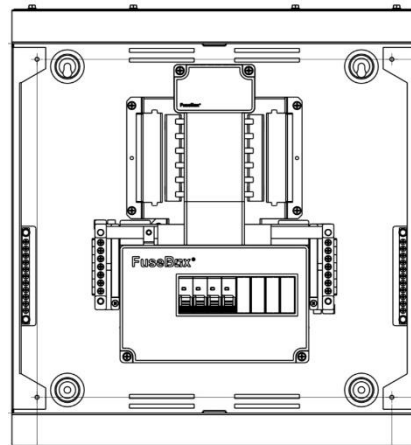

TPN03FBX

125A 3WAY 4P MAIN SWITCH+SPD

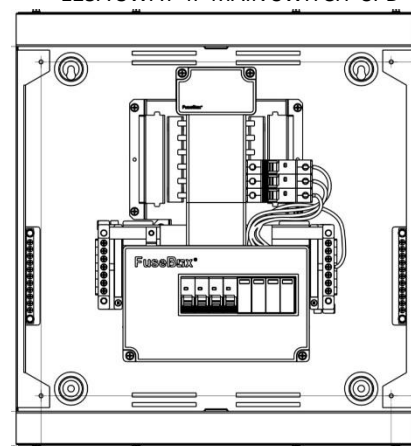

Technical information

- 1a Distribution Board must be installed by a qualified electrician in accordance with the current IET Wiring Regulations BS 7671
- 1b Total load must not exceed the rating of the incoming isolator or any additional limitation.
- 1c The total sum of the individual MCBs may exceed this value where there is appropriate diversity in the installation.
- 1d The distribution board and associated components have been manufactured to the following specifications (table 1).
- 1e Ambient Temperature: MCBs are calibrated at 30°C according to the calibration temperature requirements of EN60898. At other temperatures the following rating factors should be used: At 60°C 0.85 At 20°C 1.0 At 0°C 1.15
- 1f Adjacent thermal-magnetic MCBs should not be continuously loaded at their nominal rated currents when mounted in enclosures. We recommend a 60% de-rating factor is applied to the MCBs nominal rated current where it is intended to load the MCBs continuously.

2 Enclosure Mounting

- 2a Remove front cover and door assembly (4x screws). Front cover assembly should be pivoted on the LHS then lifted forward.
- 2b Gland plates are fitted top and bottom and should be removed if drilling holes to prevent swarf inside the enclosure. In order to maintain the IP rating and fire containment of the enclosure we recommend glands are used.
- 2c Fix base to wall using 4 screws and rawl plugs as appropriate and remove any debris from inside the Distribution Board.
- 2d Adjust to the square.
- 2e Route incoming cables to desired positions.

ATTENTION

ENSURE SUPPLY IS SAFELY ISOLATED BEFORE COMMENCING INSTALLATION



3 Connection of Tails

- 3a Cut and dress the main incoming cables and earth conductor.
- 3b Connect into the appropriate terminals on Main Switch / RCD and earth terminal bar and torque (TABLE 2).

4 Connections

- 4a Cut, dress and connect circuit conductors to appropriate MCBs neutral and earth terminals.
- 4b ALL CONNECTIONS (including factory made connections) MUST BE TORQUED (TABLE 2).
- 4c Make sure that each earth and neutral outgoing circuit is correctly made to the corresponding numbered terminals as this will ensure final testing and fault finding is easier.

5 Circuit Identification

- 5a All circuits must be clearly labelled on the front cover.

6 Enclosure Earthing

- 6a An M8 bolt is fitted on the base.

7 Operation of the TEST button on RCD/RCBOs

- 7a When newly fitted systems do not trip on the TEST button of the RCD/RCBO or using the RCD tester the problem is normally caused by an earth to neutral fault on the circuit (PME supply).

8 Testing

- 8a After completion of the installation, it must be tested in accordance with the latest edition of the IET Wiring Regulations for Electrical Installations (BS 7671).

Before fitting the front cover, check all connections including factory made connections are TORQUED (table 2).
Loose connections can cause fires!

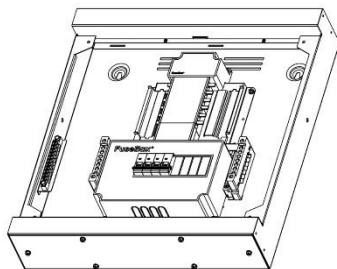

TPN RANGE

Part number	Description
SPDCUKITT2TPN	T2 SPD 3P+NPE (INC CABLES+3P B32 MCB)
TPN03FBX	TPN DB 3 WAY SPD 125A MS
TPN04FB	TPN DB 3 WAY SPD 125A MS
TPN07FBX	TPN DB 7 WAY SPD 125A MS
TPN08FB	TPN DB 8 WAY 125A MS
TPN11FBX	TPN DB 11 WAY SPD 125A MS
TPN12FB	TPN DB 12 WAY 125A MS
TPN15FBX	TPN DB 15 WAY SPD 125A MS
TPN16FB	TPN DB 16 WAY 125A MS
TPNEFB	TPN EXTENSION BOARD 14MOD
TPNSPLFB	TPN SINGLE PHASE FORK 125A

1 Pole 10kA MCB			
Current rating	B curve	C curve	D curve
6A	MT10B061	MT10C061	MT10D061
10A	MT10B101	MT10C101	MT10D101
16A	MT10B161	MT10C161	MT10D161
20A	MT10B201	MT10C201	MT10D201
25A	MT10B251	MT10C251	MT10D251
32A	MT10B321	MT10C321	MT10D321
40A	MT10B401	MT10C401	MT10D401
50A	MT10B501	MT10C501	MT10D501
63A	MT10B631	MT10C631	MT10D631

2 Pole 10kA MCB		
Current rating		D curve
6A		MT10D062
10A		MT10D102
16A		MT10D162
20A		MT10D202
25A		MT10D252
32A		MT10D322
40A		MT10D402
50A		MT10D502
63A		MT10D632

3 Pole 10kA MCB			
Current rating	B curve	C curve	D curve
6A	MT10B063	MT10C063	MT10D063
10A	MT10B103	MT10C103	MT10D103
16A	MT10B163	MT10C163	MT10D163
20A	MT10B203	MT10C203	MT10D203
25A	MT10B253	MT10C253	MT10D253
32A	MT10B323	MT10C323	MT10D323
40A	MT10B403	MT10C403	MT10D403
50A	MT10B503	MT10C503	MT10D503
63A	MT10B633	MT10C633	MT10D633

RCBO 1 P+N 10kA			
Current rating	B curve	C curve	
6A	RTA100630B	RTA100630C	
10A	RTA101030B	RTA101030C	
16A	RTA101630B	RTA101630C	
20A	RTA102030B	RTA102030C	
25A	RTA102530B	RTA102530C	
32A	RTA103230B	RTA103230C	
40A	RTA104030B	RTA104030C	
50A	RTA105030B	RTA105030C	
63A	RTA106330B	RTA106330C	

www.fusebox.co.uk

