



VENTO MAXI AIR | VENTO MIDI AIR | VENTO MINI AIR | VENTO DUO AIR



SINGLE-ROOM HEAT RECOVERY UNIT

EXTRACTOR FAN

POSITIVE INPUT VENTILATOR

DECENTRALISED MECHANICAL EXTRACT UNIT

# Energy Saving Ventilation for the Home



## Blauberg Vento is a revolutionary way to ventilate your home.

Without adequate ventilation, you put your home at risk of mould and damp caused by humidity and condensation, as well as trapping in stale air which often contains CO<sub>2</sub>, VOCs, radon, particulate matter and more.

Inadequate ventilation can have a negative impact on both your health and your home. Poor air quality can lead to health problems like COPD, lung cancer and asthma.

However, ventilating efficiently isn't easy. Cracking open windows in the mid-winter can lead to heat loss and an influx of dirty air containing dust, combustibles and particulate matter.

Whilst mechanical ventilation can be a powerful way to ventilate your home, it's also a costly measure when you have to account for heat loss through the extraction process.

Blauberg MVHR Vento units are a revolutionary way to ventilate your home as they strike a balance between powerful ventilation and energy efficiency.

Depending on the unit you choose, **you could recover up to 95% of heat, meaning that for every £1 spent on energy to heat the room, 95p of it can be recovered whilst maintaining ventilation.**

Extracting air using traditional ventilation would cause the home to lose this heat / energy thus costing money.

These units extract stale warm air and introduce fresh air from outside, which is then filtered and passed over a heat exchanger to transfer the recovered heat from the extract process into your fresh supply of air. The result is fresh, filtered warm air for maximum comfort and breathability.

All Vento units run effectively all year round, can be smartphone controlled, are home assistant compatible and Wi-Fi-enabled to run on their own or collectively, should you choose to install more than one.

## There are four sizes of Vento units to choose from:

**VENTO MINI for rooms up to 10sqm** - Up to 81% heat recovery efficiency. Designed for Bedrooms and Quiet Rooms. Also fit for Garden Buildings.

**VENTO MIDI for rooms up to 20sqm** - Up to 95% heat recovery efficiency. Designed for Living and Dining Rooms. Also fit for Bedrooms, Living Rooms, Dining Rooms, Garden Buildings.

**VENTO MAXI for rooms up to 35sqm** - Up to 87% heat recovery efficiency. Designed for Kitchens and Utility Rooms. Also fit for Bedrooms, Living Rooms, Dining Rooms, Offices, Garden Buildings and Temporary and Mobile Buildings.

**VENTO DUO** - Up to 85% heat recovery efficiency. Designed for Toilets, Bathrooms and Wet Rooms. Also fit for Kitchens and Utilities.

## How do Ventos work?

**Vento Maxi, Midi and Mini** work in cycles. They ventilate your home year-round and recover heat in the winter and expel excess warm air in the summer, allowing you to experience a stable indoor temperature regardless of the outdoor climate.

In winter operating mode, the first cycle extracts dirty air for 70 seconds and transfers any heat to the energy core.

After 70 seconds, the second cycle reverses the airflow, collects the recovered heat from the energy core and supplies fresh, filtered warm air into your home.

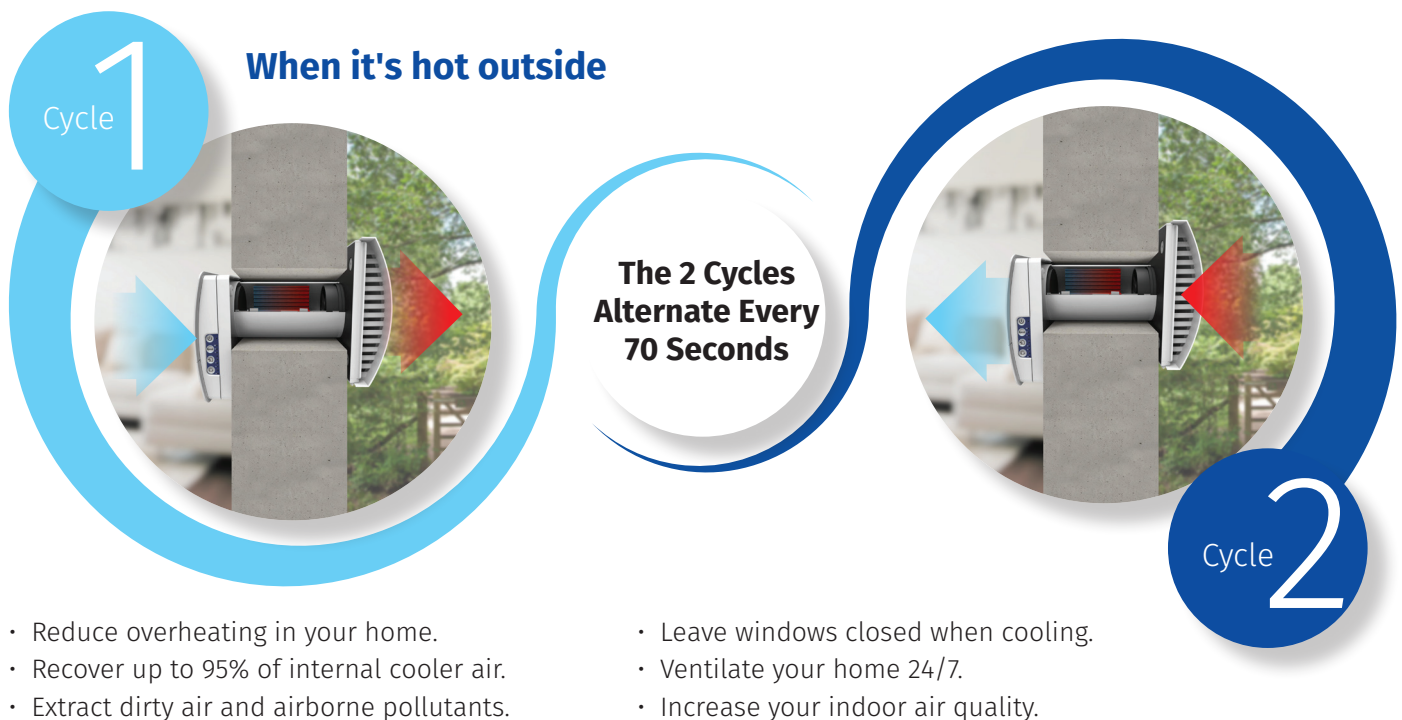
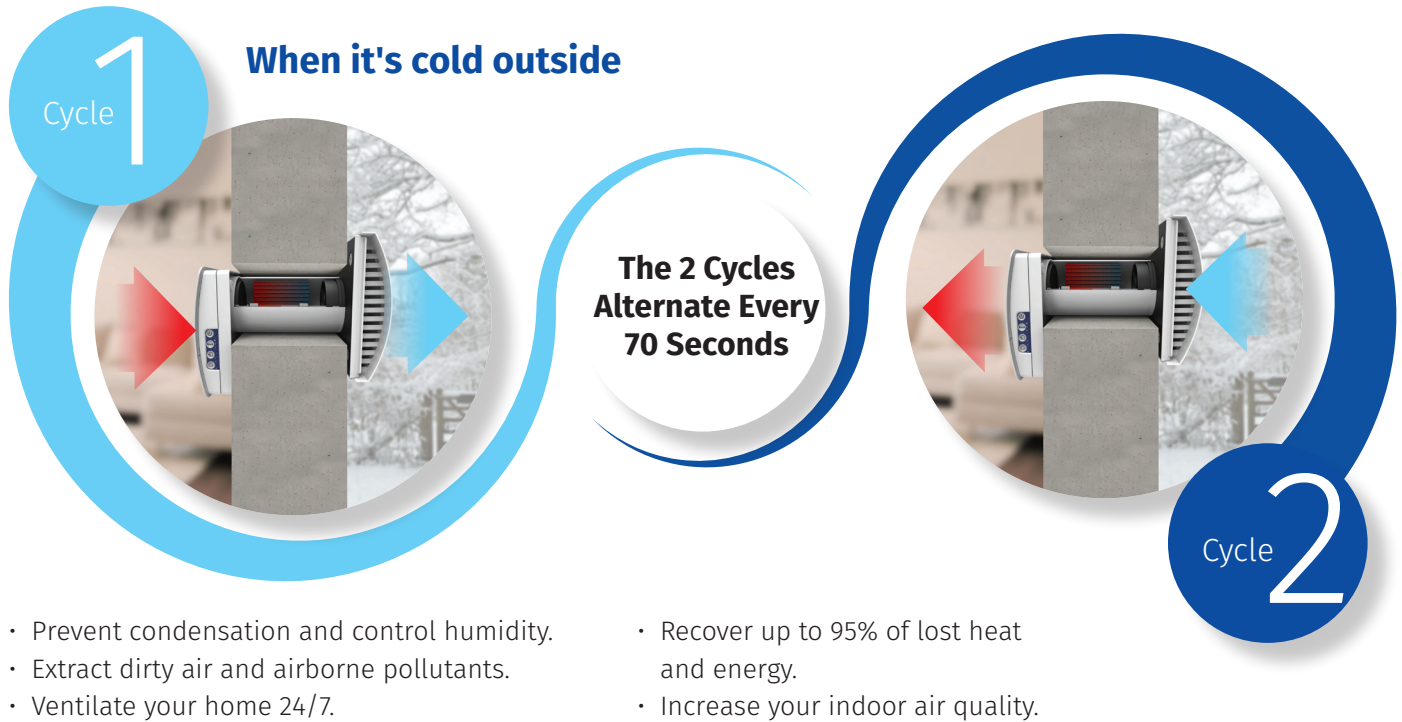

The **Vento Duo** is designed for kitchens, utility rooms, wet rooms and bathrooms. They have the same capabilities as the other Vento models but contain two low-energy motors

as the heat exchanger is divided into two parts. This allows for constant extract and airflow.

# How to Control your Vento's

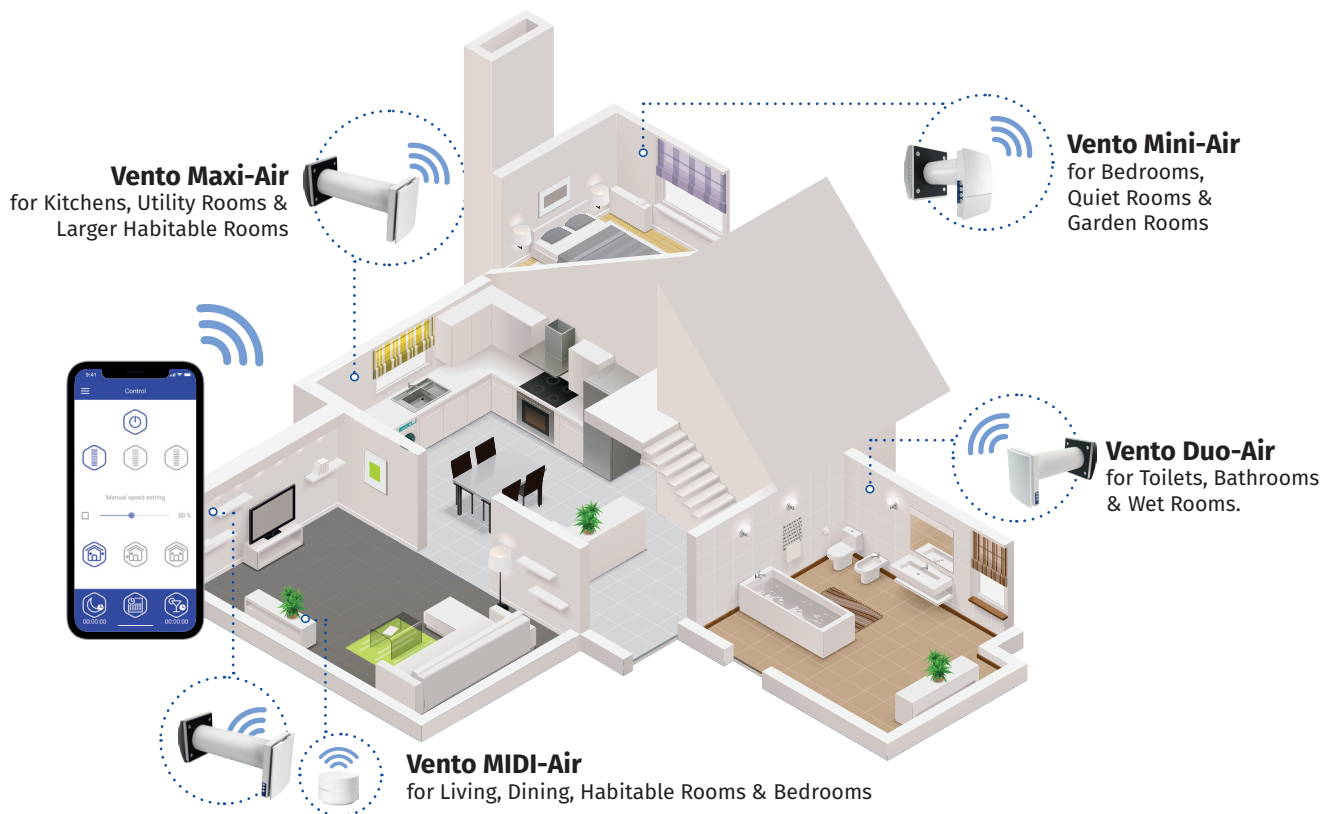

## Local Control

All Vento units have locally mounted controls for basic functionality, so you can:

- Switch off and select low, medium and boost speeds.
- Activate heat recovery mode.
- Switch to active ventilation (extract or supply air).
- Have a visual indication of alarms and unit statistics



- Speed Selection and Off
- Heat Recovery Mode
- Ventilation Mode
- Alarms

## Control via smartphone, home assistant or through The Cloud

For full functionality download the Blauberg Vento app, where you can access all of the controls for your ventilation system. You can:

- Control units collectively or independently.
- Switch between ventilation modes: energy and heat recovery, PIV (positive input) and intermittent extract.
- Schedule ventilation with the built-in 24-hour, 7-day calendar.
- Set speed levels and timers and view external sensors.
- View warnings and alarms.
- Set up connections for Wi-Fi and access through The Cloud.
- Integrate your ventilation system into your smart home with Alexa or Google Assistant.

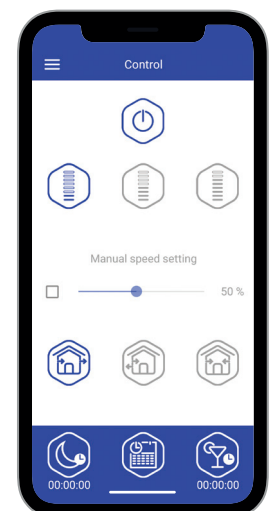

## Connect to Alexa or Google Play Virtual Assistant



Integrate your energy saving ventilation system into your smart home with Alexa and Google Play integration.

- Control each unit collectively or independently.
- Switch between all ventilation modes: energy and heat recovery, PIV (positive input), intermittent extract and decentralised ventilation.
- Set dates and times with the built-in 24 hour, 7 day calendar.
- Set speed levels, boost, timers and external sensors such as CO<sup>2</sup> and VOC's.
- View warnings and alarms.
- Set up connections for home, Wi-Fi and access through the cloud.

## Setting up your Vento units

If you've opted for more than one unit, you can choose one to act as the 'primary' unit and the rest as the 'secondary' units.

The primary unit will use Wi-Fi to act as a communication hub for the secondary units, sending all information and settings to each secondary device.

## Typical House Layout



## Certification



All Blauberg Vento units are TÜV Certified. This is a highly recognised, worldwide trademark of trust and quality. A TÜV certification ensures that a product, service, or process has been tested for safety and that it complies with the requirements of national, regional and international regulations. It assures consumers that the product has been checked thoroughly for any defects or potentially dangerous materials.

All Blauberg Vento units are DIBt Certified. This highly esteemed certificate is reserved for the very highest quality, German-made products. It also certifies the heat and energy recovery rates tested at Stuttgart University Laboratory.

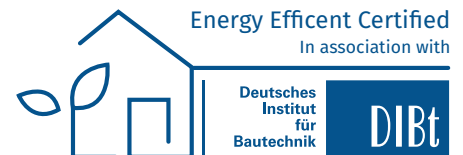

All Blauberg Vento units are tested at Stuttgart University Laboratories; one of only a few test facilities in the world that is capable of testing decentralised ventilation heat recovery units. Not only does this confirm that Vento units are manufactured to British Standards BS EN 13141-8, it certifies energy consumption and more importantly, the heat recovery and energy recovery rates.

# Vento Maxi-Air | Kitchens, Utility Rooms & Larger Habitable Rooms



Kitchens, Utility Rooms & Larger Habitable Rooms.

Airflow rate up to 30 l/s.

Up to 87% heat recovery.

Low energy: from 4.45w.

Low Noise Level.



## Technical Data

Parameters	Vento Maxi-Air			
Speed	I	II	III	MAX
Voltage - (V) 50 (60) Hz	100-230			
Power - Watts (W)	3.2	4.00	6.6	18
Current - Amps (A)	0.037	0.046	0.071	0.151
Speed - RPM	780	1100	1920	2940
<b>Intermittent Extractor Fan Mode - IEF</b>				
Maximum Airflow litres per second (l/s)	5	8	16	30
Minimum Specific Fan Power SFP - (w/l/s)	0.64	0.5	0.41	0.6
<b>Positive Input Ventilation Mode - PIV</b>				
Maximum Airflow litres per second (l/s)	5	8	16	30
Minimum Specific Fan Power SFP - (w/l/s)	0.64	0.5	0.41	0.6
<b>Decentralised Heat Recovery Ventilation Mode - dMVHR</b>				
Maximum Airflow litres per second (l/s)	3	4	8	15
Minimum Specific Fan Power SFP - (w/l/s)	1.06	1.06	0.83	1.2
<b>Decentralised Mechanical Extract Ventilation Mode - dMEV</b>				
Maximum Airflow litres per second (l/s)	5	8	16	30
Minimum Specific Fan Power SFP - (w/l/s)	0.64	0.5	0.41	0.6
Filter	G3 (F8 available as an optional extra)			
Transported air temperature - (°C)	-20 - +40			
Sound pressure level at 3 m - (dBA)	13	18	30	42
Heat recovery thermal efficiency - (%)	up to 87			
Ingress protection rating - (IP)	24			

**ENERG**  
енергия · ενεργεια  
Y U/A  
IE IA

**BLAUBERG** Vento Maxi-Air

**A+**

**A**

**B**

**C**

**D**

**E**

**F**

**G**

**A**

**38**  
dB

**100 m<sup>3</sup>/h**

ENERGIA - ΕΝΕΡΓΙΑ - ENERGIJA - ENERGIJA - ENERGI - ENERGI - ENERGI  
2018 1254/2014

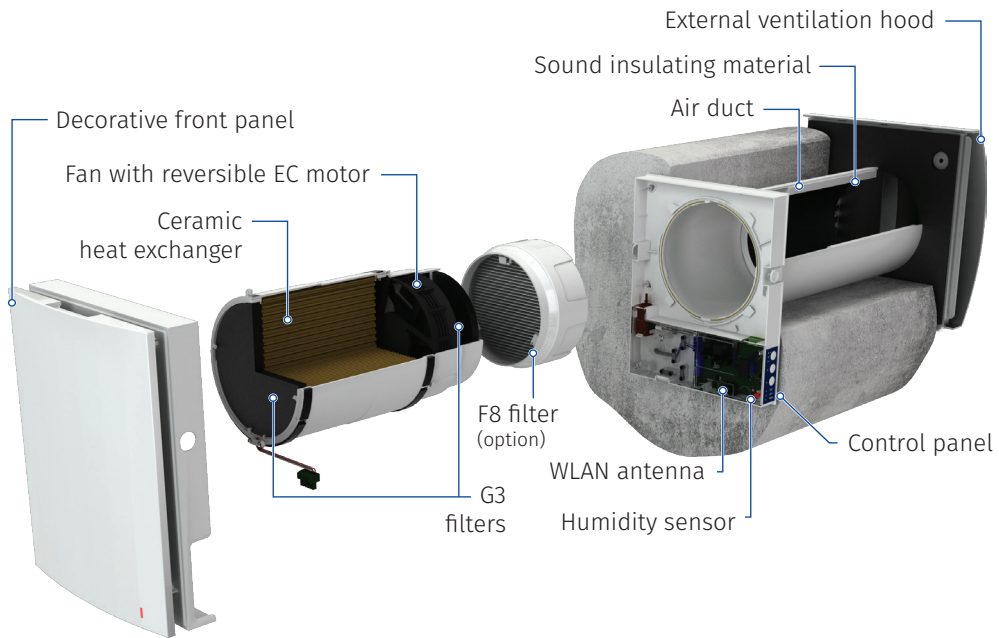



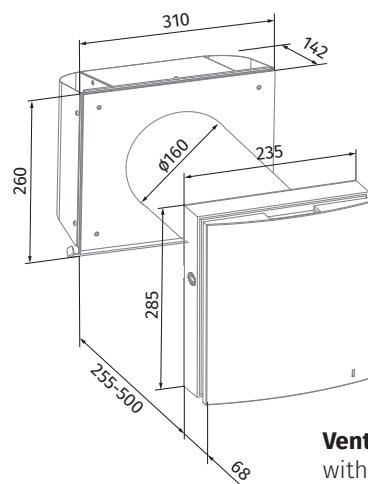
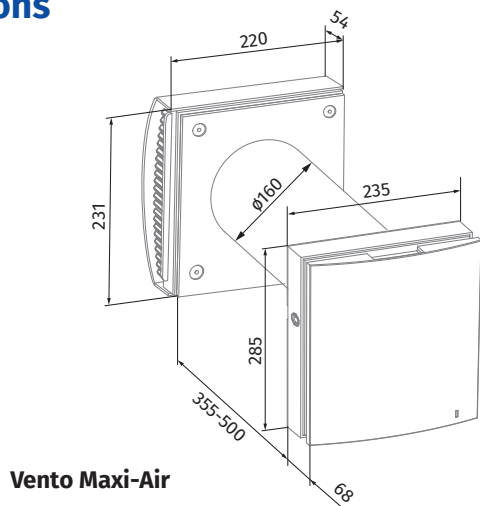

## Dimensions



# Vento Midi-Air | Living, Dining, Habitable Rooms & Bedrooms



-  Living, Dining, Habitable Rooms & Bedrooms.
-  Airflow rate up to 15 l/s.
-  Up to 95% heat recovery.
-  Low energy: from 4.45w.
-  Low Noise Level.



## Technical Data

Parameters	Vento Midi-Air		
	I	II	III
Speed			
Voltage - (V) 50 (60) Hz	100-230		
Power - Watts (W)	4.45	5.08	6.99
Current - Amps (A)	0.035	0.040	0.059
Speed - RPM	800	1300	1900
<b>Intermittent Extractor Fan Mode - IEF</b>			
Maximum Airflow litres per second (l/s)	4	8	15
Minimum Specific Fan Power SFP - (w/l/s)	1.11	0.65	0.49
<b>Positive Input Ventilation Mode - PIV</b>			
Maximum Airflow litres per second (l/s)	4	8	15
Minimum Specific Fan Power SFP - (w/l/s)	1.11	0.65	0.49
<b>Decentralised Heat Recovery Ventilation Mode - dMVHR</b>			
Maximum Airflow litres per second (l/s)	2	4	7
Minimum Specific Fan Power SFP - (w/l/s)	2.23	1.27	0.99
<b>Decentralised Mechanical Extract Ventilation Mode - dMEV</b>			
Maximum Airflow litres per second (l/s)	4	8	14
Minimum Specific Fan Power SFP - (w/l/s)	1.11	0.65	0.49
Filter	G3 (F8 available as an optional extra)		
Transported air temperature - (°C)	-20 - +40		
Sound pressure level at 3 m - (dBA)	13	18	30
Heat recovery thermal efficiency - (%)	up to 95		
Ingress protection rating - (IP)	24		

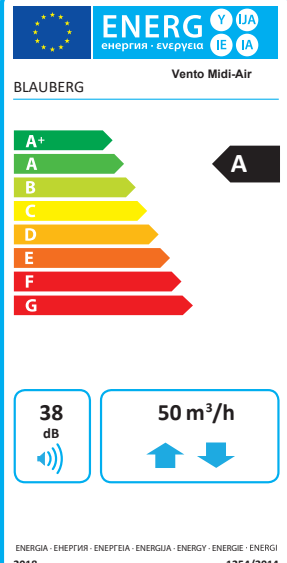

**ENERGY LABEL**  
 ENERGY LABEL Y U A IE IA  
 BLAUBERG Vento Midi-Air

Energy efficiency class: **A**

Sound power level: **38 dB**

Airflow: **50 m<sup>3</sup>/h**

ENERGIA - ENERGIJA - ENERGIJA - ENERGIJA - ENERGY - ENERGIE - ENERGI  
 2018 1254/2014



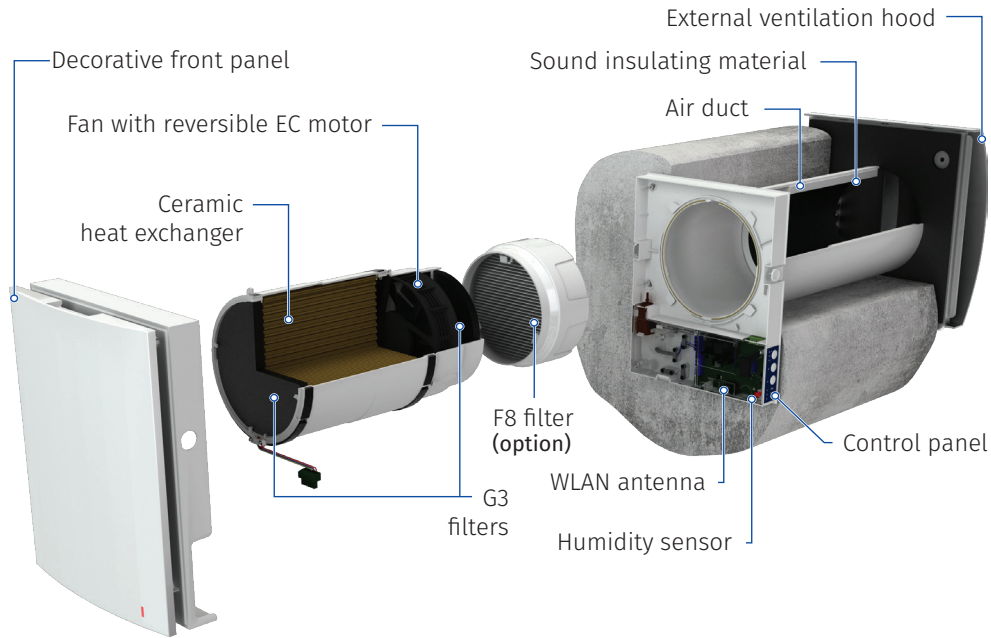

## Dimensions

### Vento Midi-Air

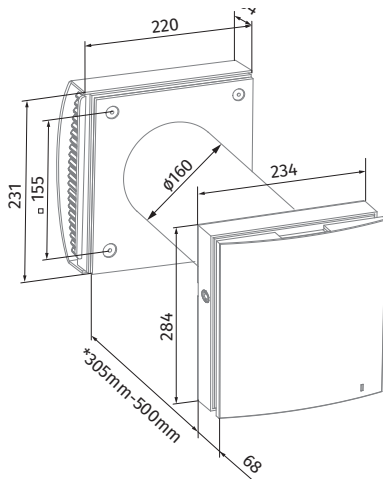



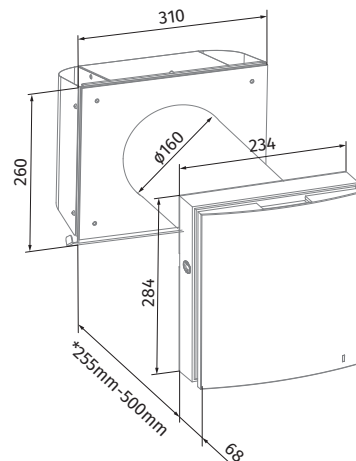

\*From 305mm without F7 Filter Cartridge housing



\*From 255mm without F7 Filter Cartridge housing using the slim wall mounting kit

# Vento Mini-Air | Bedrooms, Quiet Rooms & Garden Rooms



-  Bedrooms, Quiet Rooms & Garden Rooms.
-  Airflow rate up to 8 l/s.
-  Up to 81% heat recovery.
-  Low energy: from 1.8w.
-  Low Noise Level.

## Technical Data

Parameters	Vento Mini-Air		
	I	II	III
Speed			
Voltage - (V) 50 (60) Hz	100-230		
Power - Watts (W)	1.8	2.99	4.4
Current - Amps (A)	0.027	0.037	0.051
Speed - RPM	1600	2200	2500
<b>Intermittent Extractor Fan Mode - IEF</b>			
Maximum Airflow litres per second (l/s)	3	6	8
Minimum Specific Fan Power SFP - (w/l/s)	0.6	0.49	0.55
<b>Positive Input Ventilation Mode - PIV</b>			
Maximum Airflow litres per second (l/s)	3	6	8
Minimum Specific Fan Power SFP - (w/l/s)	0.6	0.49	0.55
<b>Decentralised Heat Recovery Ventilation Mode - dMVHR</b>			
Maximum Airflow litres per second (l/s)	1	3	4
Minimum Specific Fan Power SFP - (w/l/s)	1.8	0.99	1.1
<b>Decentralised Mechanical Extract Ventilation Mode - dMEV</b>			
Maximum Airflow litres per second (l/s)	3	6	8
Minimum Specific Fan Power SFP - (w/l/s)	0.6	0.49	0.55
Filter	G3		
Transported air temperature - (°C)	-15 - +40		
Sound pressure level at 3 m - (dBA)	21	38	31
Heat recovery thermal efficiency - (%)	up to 81		
Ingress protection rating - (IP)	24		



BLAUBERG Vento Mini-Air

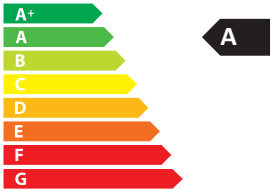

**48 dB**

**15 m³/h**

ENERGIA · ΕΝΕΡΓΙΑ · ENERGIJA · ENERGIJA · ENERGI · ENERGI · ENERGI · ENERGI  
2018 1254/2014

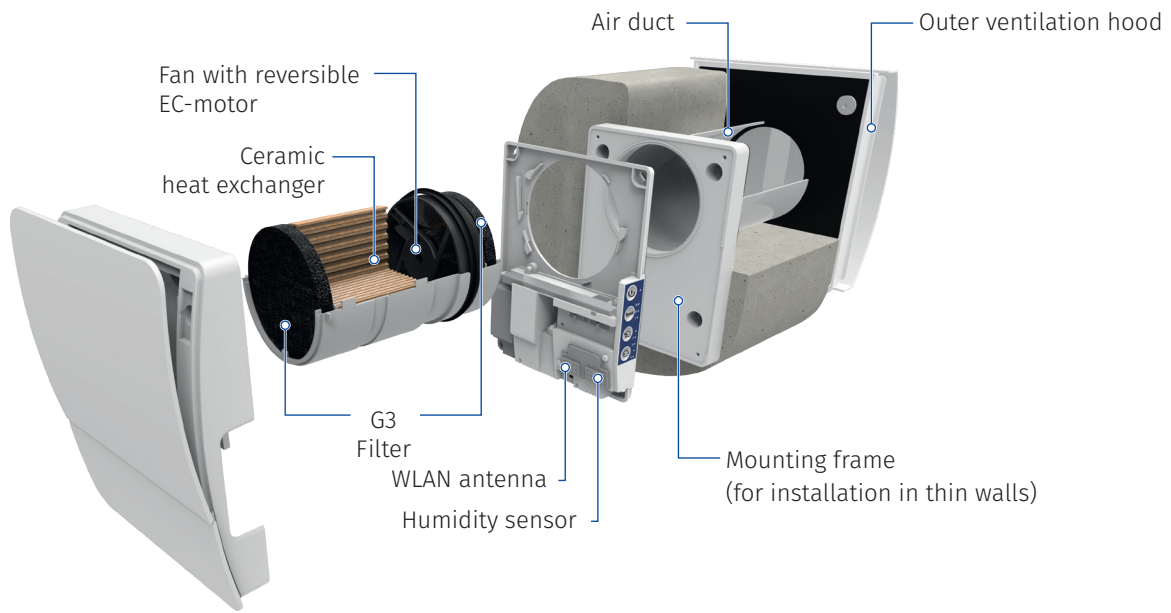

## Dimensions

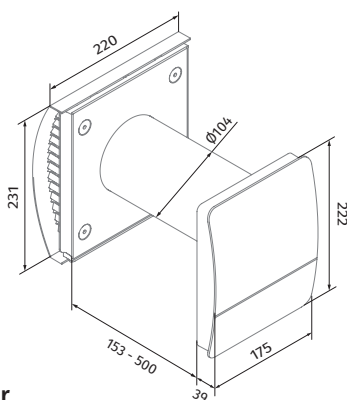

**Vento Mini-Air**

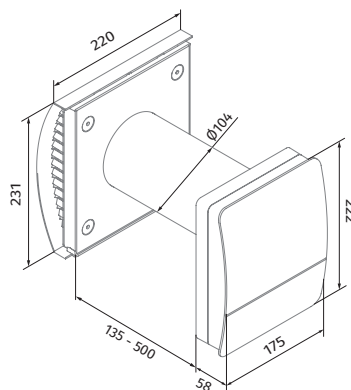

**Vento Mini-Air**  
(with a mounting frame for thin walls)



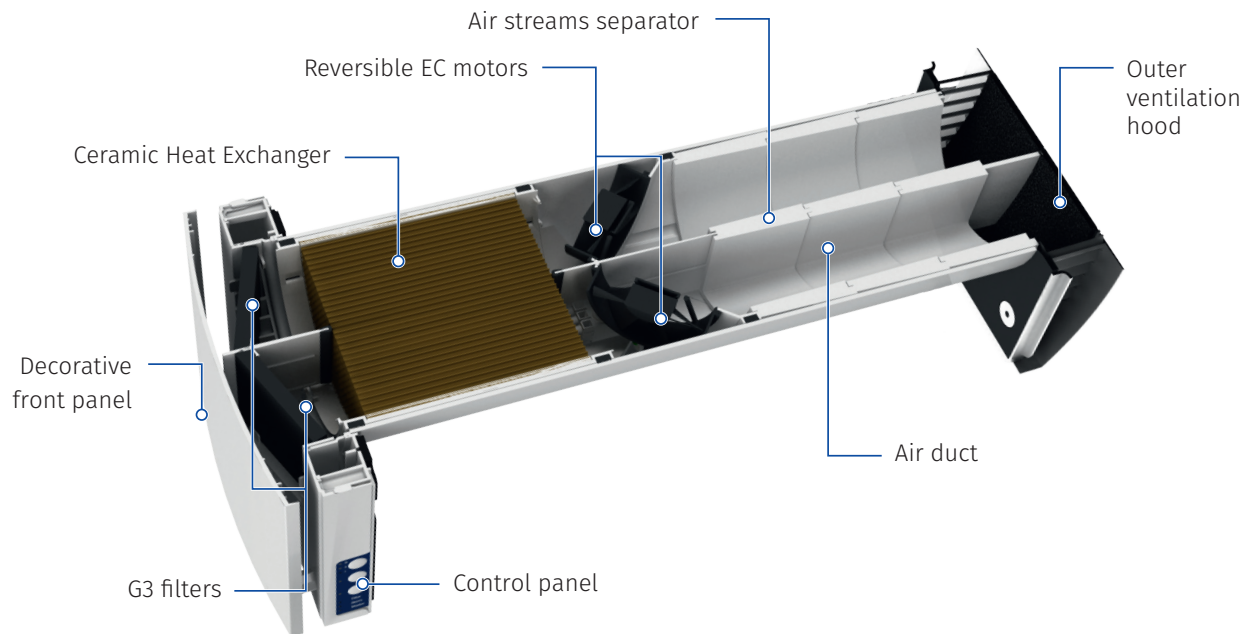

## Dimensions

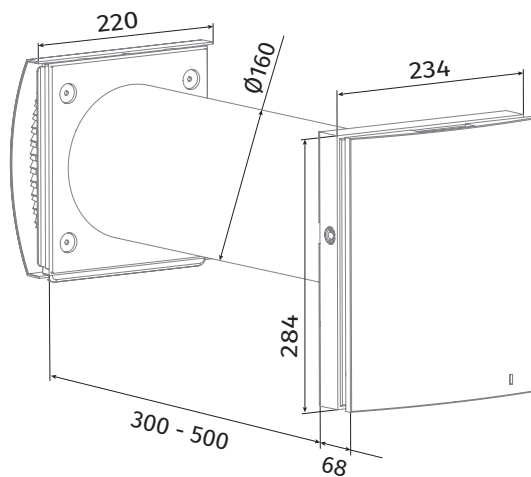

## Vento Maxi-Air

### Accessories

Name		Description
FP3 Vento G3		G3 filters (2 pcs.)
AH-10 *colour* 100		Plastic outer ventilation hood. Available colours:
BlauPlast RTR 100/0.5-1		Telescopic air duct with the diameter of 100mm and adjustable length from 500 to 1000mm.
CD-1		CO <sub>2</sub> sensor with LED CO <sub>2</sub> indication and a sensor button for operation mode selection.
FP7-Vento F7		F7 High Capacity Pleated Filter Cassette



## Vento Midi-Air

### Accessories

Name		Description
FP3 Vento G3		G3 filters (2 pcs.)
AH-10 *colour* 100		Plastic outer ventilation hood. Available colours:
BlauPlast RTR 100/0.5-1		Telescopic air duct with the diameter of 100mm and adjustable length from 500 to 1000mm.
CD-1		CO <sub>2</sub> sensor with LED CO <sub>2</sub> indication and a sensor button for operation mode selection.
FP7-Vento F7		F7 High Capacity Pleated Filter Cassette

# Vento Mini-Air

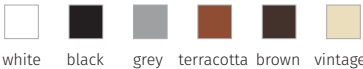
## Accessories

Name		Description
FP3 Vento G3		G3 filters (2 pcs.)
AH-10 *colour* 100		Plastic outer ventilation hood. Available colours: 
BlauPlast RTR 100/0.5-1		Telescopic air duct with the diameter of 100mm and adjustable length from 500 to 1000mm.
CD-1		CO <sub>2</sub> sensor with LED CO <sub>2</sub> indication and a sensor button for operation mode selection.

# Vento Duo-Air

## Accessories

Name		Description
FP Vento Expert Duo A30 G3		G3 filters (2 pcs.).
AH-10 *colour* 160 Duo		Plastic outer ventilation hood. Available colours: 
LST Vento Expert Duo		Air stream separator.
CD-1		CO <sub>2</sub> sensor with LED CO <sub>2</sub> indication and a sensor button for operation mode selection.



**Blauberg UK Ltd.**

Unit E, 99 Boston Road,  
Leicester,  
LE4 1AW

[www.blauberg.co.uk](http://www.blauberg.co.uk)  
[technicalsupport@blauberg.co.uk](mailto:technicalsupport@blauberg.co.uk)  
0116 216 0650